

Protection of BLDC Motors from Tolerant Torque

Ashwini Thote, Aniket Balki, Karishma Khuspure, Priyanka Ghodmare, Shubham Dhuriya, Bharti Nande, Prof. Abhay Halmare

Department of Electrical Engineering, KDK College of Engineering, Nagpur, Maharashtra, India

ABSTRACT

Fault tolerance is critical for bldc motor used in high-risk applications, such as E-Bike, E-Riksha, Aerospace, Robot and Military. These motors should be capable of continued functional operation, therefore from the tolerant torque, motor may be damage like burning of winding, failure of hall effect sensor and the failure of motor controller. This paper present protection of bldc motor from the tolerant torque by sensing the current from the current sensor by using the PIC microcontroller, where current sensor sense the current from the motor terminal then send the signal to the microcontroller, then microcontroller is program, program like may be setting of current with respect to time. Means at starting time force required more therefore current required more. It means that tolerant torque is increasing. The controller allow the current for the certain small time, otherwise controller trip the circuit.

Keywords : BLDC Hub Motors, Brushless Motors, Fault Detection, Fault Tolerant Control, Embedded C Programming, Torque Control, Protection.

I. INTRODUCTION

BRUSHLESS dc (BLDC) motors are commonly used in applications, such as robotics and automation, aerospace, vehicles, computed numerically controlled machines, manufacturing, and military. The importance of employing reliable motor drive systems in many of these application is paramount. In particular, for space application, it is highly desirable to use fault-tolerant (FT) actuators to drive the joints of a manipulator or wheels of a rover. Permanent-magnet synchronous motors, also known as BLdc motors, are commonly used as the drives of servo systems.

BLDC motors are composed of a rotor containing a series of permanent magnets and the armature, which remains static while the electric power is distributed by an electronically controlled commutation system, instead of a mechanical commutator using brushes. BLDC motors offer several advantages over brushed dc motors making them suitable for use as servomotors. Those include higher reliability, efficiency, and longer lifetime because of the absence of electrical and friction losses as well as erosion due to brushes. Moreover, BLdc motors can be completely sealed off and protected from dirt, oil, grease, and other types of foreign matter. Nevertheless, even a BLdc motor is subject to a variety of failures, which may occur during its operation.

II. METHODS AND MATERIAL

Block diagram consist of hub bldc motor, motor controller, pic controller, throttle ,lead-acid batteries, current transducer.

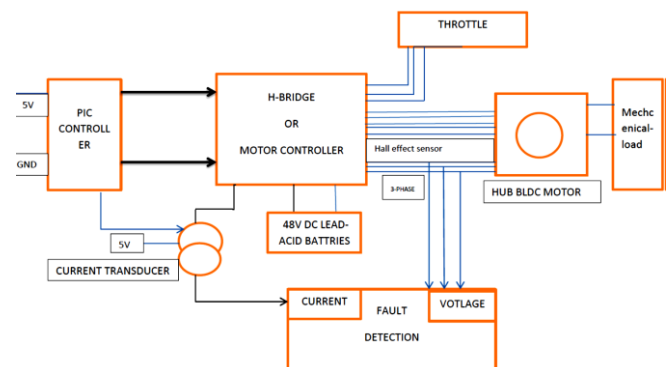

Figure 1. Block diagram

A. Hub BLDC Motor

The hub motor is a conventional Dc motor. The rotor is outside the stator with the permanent magnets mounted on inside. The stator is mounted and fixed onto the axle and the hub will be made to rotate by alternating

currents supplied through batteries. Hub motor generates high torque at low speed, which is highly efficient and which doesn't need sprockets, brackets and drive chains. This means they are very reliable and have a long life.

The main characteristic of Brushless DC Machines is that they may be controlled to give wide constant power speed ranges.

TABLE I
SPECIFICATION OF HUB BLDC MOTOR

Type of motor	HUB motor
Design of motor	BLDC motor
Power	250W
Voltage	48V
Current	<18A
Under protection voltage	42V
Noise(dB)	<65

B. Accelerator/Throttle

The maximum speed of a bicycle is 30 kmph. It is required to vary the speed depending upon the road conditions & traffic. Therefore an accelerator or a throttle is necessary. Throttle allows us to drive the motor from zero speed to full speed. The throttle is fitted on right side of the handle bar and is connected to controller.

The throttle converts DC voltage from battery to an alternating voltage with variable amplitude and frequency that drives the hub motor at different speeds. It consists of MOSFET transistors and a small microprocessor. This throttle is technically referred to as a Hall Effect type. The throttle has three wires contains a black, red, and green. The supply voltage is via red and black wires and is usually around 4 volts. Green wire voltage increases as the throttle is turned.

C. Motor Controller

The motor controller is an important component of the system. It is essential to control the amount of power supplied and to drive the BLDC hub motor. The controller converts the DC voltage from battery to an alternating voltage with variable amplitude and

frequency that drive the hub motor at different speeds. It basically consists of MOSFET transistors and small microprocessor that vary from detecting any malfunctions with the motor hall sensors, the throttle, to protect functions against excessive current and under-voltage, which are ideal for protecting the system.

D. Lead Acid Battery

Lead acid batteries are one of the most popular types of battery in electronics. Although slightly lower in energy density than lithium metal, lead acid is safe, provided certain precautions are met when charging and discharging. This have a many advantages over other conventional types of batteries, the lead acid battery is the optimum choice for a solar assisted bicycle. Current supplied from battery indicates the flow of energy from the battery and is measured in amperes (or Amps).

The higher the current flow faster the battery will discharge. A battery is rated in ampere-hours (abbreviated Ah) and this is called the battery capacity. This project revolves around supplying and utilizing energy within a high voltage battery. It demands for a battery with longer running hours, lighter weight with respect to its high output voltage and higher energy density. Among all the existing rechargeable battery systems, the lead acid cell technology is the most efficient and practical choice for the desired application. The battery chosen for this project was a high capacity lead acid battery pack designed specifically for vehicles. Plastic casing is provided to house the internal components of the battery.



Figure 2. Lead-acid battrey

TABLE 2

SPECIFICATION OF LEAD-ACID BATTERIES

Type of battery	Sealed lead acid
Number of batteries	Four batteries connected in series
Voltage	12V
Amp-Hour rating	8Ah

E. PIC Controller

PIC is a family of microcontroller made by Microchip Technology, drives from the PIC1650 originally developed by General Instrument's. Microelectronics Divisions. The name PIC initially referred to Peripheral Interface Controller. The first parts of the family were available in 1976; by 2013 the company had shipped more than 12 billion individual parts used in wide variety of embedded systems.

Early models of PIC had read-only memory (ROM) or field-programmable EPROM for program storage some with provision for erasing memory. All current models use flash memory for program storage and newer models allow the PIC to reprogram itself. Program memory and data memory are separate. Data memories is 8-bit, 16-bit and in latest models, 32-bit wide. Program instructions vary in bit count by family of PIC and may be 12, 14, 16 or 24 bits long. The instruction set also varies by mode, with more power full chips adding instructions for digital signal processing functions.

F. Current Transducer

A current sensor is a device that detects electric current (AC or DC) in a wire, a generates a signal proportional to it. The generated signal could be analog voltage or current or even digital output. It can be then utilized to display the measured current in an ammeter or can be stored for futher analysis in a data acquisition system or can be utilized for control purpose.

III. RESULTS AND DISCUSSION

1. Working

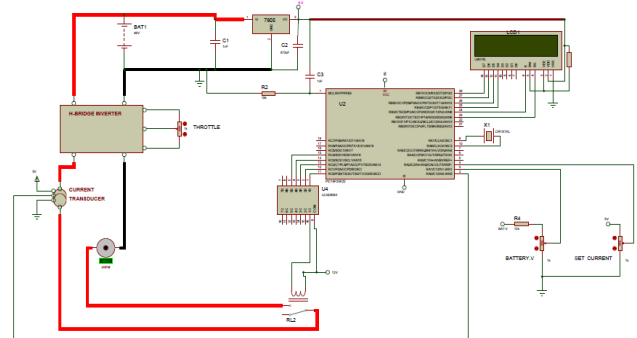

Figure 3. Circuit Diagram

Battery connected to the H-bridge therefore H-bridge generates PWM send to the motor. According to the detection of poles by the hall effect sensors motor start run, motor coupled with mechanical load, where PIC controller connected to the H-bridge. When the load increase on the motor, therefor may be current increase, in that case PIC controller having setting of current. Therefore when the motor exceeds the setting of current in the micro-controller. In that time, controller tipped the circuit, from that the result may be when the current increase. Therefore in that result may be cause failure of that effect. According to this circuit overall protection done in the BLDC motor having reliable working.

Current Observer:

For sensing the current from current transducer are used from the calibration in this may be done. In PIC controller setting may be done,512 bytes may be current is zero or current setting may be change by potentiometer therefore 1024bytes. Suppose current setting may be done at 1024 in that case calculation of current may become.

$$I_{blde} = \frac{(\text{Current setting- Intial current}) * 20}{1024}$$

Voltage Observer:

Voltage may be send by the battery by 48V DC this voltage may be constant. Therefore it does not requires any protection. In case of voltage may be reduces. Motor does not operate in that condition. But battery

having constant voltage, may be very less chance of voltage reduces.

2. Experiment

A. Experiment Setup



Figure 4. Experiment setup

B. Performance Test

TABLE3

% Throttle	Load(kg)	Current(A)
20%	19.8 Kg	1.32 A
40%	30 Kg	2.71 A
60%	39.89Kg	3.81 A
80%	41.32Kg	4.2 A

IV. CONCLUSION

The protection of BLDC motor may be done from the tolerant torque . By using current transducer and PIC microcontroller. Current transducer sense current in the form of calibration that signal takes the PIC microcontroller the sense current may be greater than the setting of PIC controller circuit may be tripped . Therefore, failure of hall effect sensor and the burning of winding may be eliminated.

V. REFERENCES

- [1]. Y. Murai, Y. Kawase, K. Ohashi, K. Nagatake, and K. Okuyama, "Torque ripple improvement for brushless dc miniature motors," *IEEE Trans. Ind. Appl.*, vol. 25, no. 3, pp. 441–450, May/Jun. 1989.
- [2]. N. Matsui, T. Makino, and H. Satoh, "Autocompensation of torque ripple of direct drive motor by torque observer," *IEEE Trans. Ind. Appl.*, vol. 29, no. 1, pp. 187–194, Jan./Feb. 1993.
- [3]. D. G. Taylor, "Nonlinear control of electric machines: An overview," *IEEE Control Syst. Mag.*, vol. 14, no. 6, pp. 41–51, Dec. 1994.
- [4]. C. French and P. Acarnley, "Direct torque control of permanent magnet drives," *IEEE Trans. Ind. Appl.*, vol. 32, no. 5, pp. 1080–1088, Sep./Oct. 1996.
- [5]. F. Aghili, M. Buehler, and J. M. Hollerbach, "Optimal commutation laws in the frequency domain for PM synchronous direct-drive motors," *IEEE Trans. Power Elect.*, vol. 15, no. 6, pp. 1056–1064, Nov. 2000.
- [6]. S. J. Park, H. W. Park, M. H. Lee, and F. Harashima, "A new approach for minimum-torque-ripple maximum-efficiency control of BLDC motor," *IEEE Trans. Ind. Elect.*, vol. 47, no. 1, pp. 109–114, Feb. 2000.
- [7]. F. Aghili, M. Buehler, and J. M. Hollerbach, "Experimental characterization and quadratic programming-based control of brushless-motors," *IEEE Trans. Control Syst. Technol.*, vol. 11, no. 1, pp. 139–146, Jan. 2003.
- [8]. Y. Wang, D. Cheng, C. Li, and Y. Ge, "Dissipative Hamiltonian realization and energy-based L2-disturbance attenuation control of multimachine power systems," *IEEE Trans. Autom. Control*, vol. 48, no. 8, pp. 1428–1433, Aug. 2003.
- [9]. O. Moseler and R. Isermann, "Application of model-based fault detection to a brushless dc motor," *IEEE Trans. Ind. Electron.*, vol. 47, no. 5, pp. 1015–1020, Oct. 2000.
- [10]. S. Nandi, H. A. Toliyat, and X. Li, "Condition monitoring and fault diagnosis of electrical motors-a review," *IEEE Trans. Energy Convers.*, vol. 20, no. 4, pp. 719–729, Dec. 2005.
- [11]. M. A. Awadallah and M. M. Morcos, "Diagnosis of stator short circuits in brushless dc motors by monitoring phase voltages," *IEEE Trans. Energy Convers.*, vol. 20, no. 1, pp. 246–247, Mar. 2005.
- [12]. M. A. Awadallah and M. M. Morcos, "Automatic diagnosis and location of open-switch fault in brushless dc motor drives using wavelets anneurofuzzy systems," *IEEE Trans. Energy Convers.*, vol. 21, no. 1, pp. 104–111, Mar. 2006.

- [13]. S. Rajagopalan, J. M. Aller, J. A. Restrepo, T. G. Habetler, and R. G. Harley, "Analytic-wavelet-ridge-based detection of dynamic eccentricity in brushless direct current (bldc) motors functioning under dynamic operating conditions," *IEEE Trans. Ind. Electron.*, vol. 54, no. 3, pp. 1410–1419, Jun. 2007.
- [14]. Z. Li, "Neural network based fault diagnosis and fault tolerant control for BLDC motor," in *Proc. IEEE 6th Int. Power Electron. Motion Control Conf.*, 2009, Wuhan, China, May, pp. 1925–1929.
- [15]. G. G. Rigatos, "Particle and kalman filtering for fault diagnosis in D motors," in *Proc. IEEE Veh. Power Propulsion Conf.*, 2009, Dearborn, MI, Sep., pp. 1228–1235.