

Performance Analysis of ZSI Fed IM Drive and VSI Fed IM Drive with Variable Load Torque

Swapnil N. Rahangdale¹, Roshan Lohe²

¹Department of Electrical Engineering, Jhulelal Institute of Technology, Nagpur, Maharashtra, India

²Assistant Engineer, Mahagenco Company Ltd., Maharashtra, India.

ABSTRACT

This paper presents comparative analysis of Z-Source inverter (ZSI) fed Induction Motor (IM) drives with mostly used Voltage Source Inverter (VSI) fed IM drives when variable load torque is applied. ZSI has both voltages buck and boost capabilities as they allow inverters to be operated in the shoot through state. It employs an exclusive Z-Source network (LC component) to dc-link the main inverter circuit to the power source. By controlling the shoot-through duty cycle, the Z-Source inverter system reduces the line harmonics, improves power factor, increases reliability and extends output voltage range. Simulation results of the conventional VSI fed IM drive are compared with the ZSI fed IM drive. Simulation results of ZSI fed IM drive when variable torque is applied, gives better performance characteristics as compared to VSI fed IM drives for speed, torque, stator & rotor current characteristics.

Keywords: PWM, Shoot- through state, Simple Boost Control, Voltage Source Inverter, Z-source inverter.

I. INTRODUCTION

The traditional inverters such as Voltage Source Inverter (VSI) and Current Source Inverter(CSI) which consists of a diode rectifier front end dc link and inverter bridge. In order to improve power factor, either an ac inductor or dc inductor is normally used. The dc link voltage is roughly equal to 1.35 times the line voltage, and the V-source inversion is a buck converter that can only produce an ac voltage limited by the dc link voltage. Because of this nature, the V-source inverter based PWM VSI are characterized by relatively low efficiency because of switching losses and considerable EMI generation. The V-source inverter based ASD system suffers the following common limitations and problems.

- 1) Obtainable output voltage is limited quite below the input line voltage. Because of the low output voltage, the output power is also lowered. This is a very undesirable situation for many applications because the motor and drive system has to be oversized for a required power.
- 2) Voltage sags can interrupt an ASD system and shut down critical loads and processes. Over 90% of

power quality related problems are from momentary (typically 0.1–2 s) voltage sags.

- 3) Performance and reliability are compromised by the V-source inverter structure, because (a) miss-gating from Electromagnetic emission(EMI) can cause shoot-through that leads to destruction of the inverter, (b) the dead time that is needed to avoid shoot-through creates distortion and unstable operation at low speeds. A recently developed new inverter, the Z-source inverter, has a niche for ASD systems to overcome the aforementioned problems.
 - ✓ ZSI can produce any desired output ac voltage, even greater than the line voltage, regardless of the input voltage, thus reducing motor ratings;
 - ✓ ZSI provides ride-through during voltage sags without any additional circuits.
 - ✓ It improves power factor and reduce and harmonic current and common-mode voltage.

II. Z -SOURCE ASD SYSTEM

Figure 1 shows the general structure of Z-Source inverter (ZSI). It employs a unique impedance network (Z-Source network) to connect the inverter main circuit to the DC power source, for providing unique features

that cannot be observed in a traditional VSI and CSI. The Z-Source network changes the circuit configuration from that of a voltage source inverter to an impedance source (i.e. Z-Source) inverter.

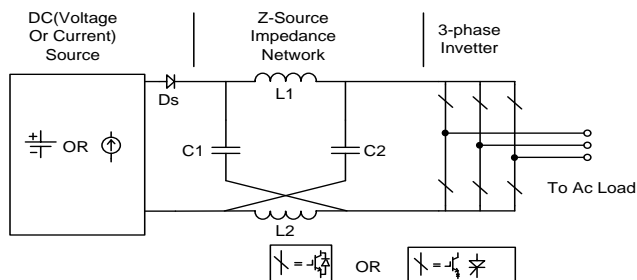

Figure 1. General Structure of Z-Source Inverter

The Z-Source network is utilized to boost the DC-link voltage to any desired level by introducing shoot through operation mode, in which the two switching devices in the same leg are simultaneously switched-on to effect a short-circuit of the DC-link. This shoot through is forbidden in traditional VSI. As the capacitors may be charged to higher voltages than the input source voltage, the diode D_s is necessary to prevent discharging of them through the input source. With this unique feature ZSI provides a cheaper, simpler and single stage approach to overcome the problems of traditional VSI fed induction motor drive. The Z-Source network consists of two inductors (L_1, L_2) and capacitors (C_1, C_2) connected in a X shape to provide an impedance source (Z-Source) coupling between the inverter and DC source. The Z-Source network provides second-order filters, which are more effective to suppress voltage ripples than the capacitor used in the traditional VSI.

III. OPERATING PRINCIPLE OF Z -SOURCE INVERTER

The operating principle and control of the ZSI can be understood by examine the general structure of ZSI as shown in Figure 1. The three-phase Z-Source inverter bridge has nine permissible switching states unlike the traditional three-phase VSI that has eight. The three-phase Z-Source inverter bridge has one extra zero state when the load terminals are shorted through both the upper and lower devices of any one phase leg, or any two phase legs, or all three phase legs. This state is forbidden in the traditional VSI, because it would cause a shoot-through, which could damage the device permanently.

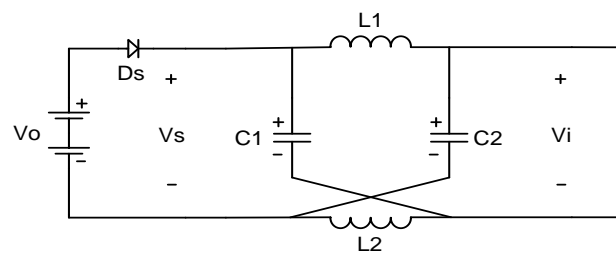

Figure 2. Equivalent circuit of the ZSI in shoot-through zero switching state

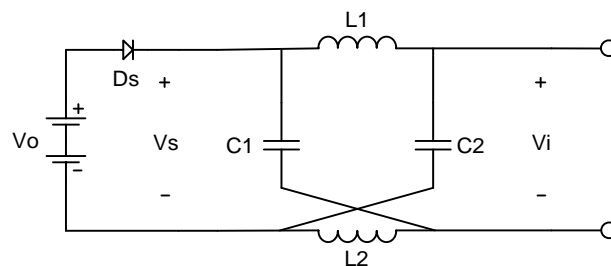

Figure 3. Equivalent circuit of the ZSI in zero switching states

The inverter bridge is equivalent to a short circuit when the inverter bridge is in the shoot-through zero state, as shown in Figure 2. Whereas inverter bridge is equivalent to open circuit when it is in one of the traditional zero state, as shown in Figure 3. And the inverter bridge becomes an equivalent current source as shown in Figure 4 when it is in one of the six active states.

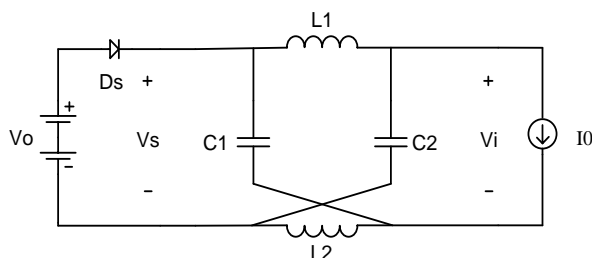

Figure 4. Equivalent circuit of the ZSI in nonshoot-through switching states

IV. INDUCTOR AND CAPACITOR REQUIREMENT FOR Z-SOURCE NETWORK

For the traditional VSI, the DC capacitor is the sole energy storage/filtering element to suppress voltage ripple and serve temporary storage. For the traditional CSI inverter, the DC inductor is the sole energy storage/filtering element to suppress current ripple and serve temporary storage. The Z-Source network is a combination of two inductors and two capacitors. This combined circuit, the Z-Source network is the energy

storage/filtering element for the ZSI. Therefore, the inductor and capacitor requirement should be smaller than the traditional inverters.

A brief discussion is given in terms of physical sizes and requirements. When the two inductors (L_1 and L_2) are small and approach zero, the Z-Source network reduces to two capacitors (C_1 and C_2) in parallel and becomes a traditional VSI. Therefore, a VSI's capacitor requirements and physical size is the worst case requirement for the ZSI. Considering additional filtering and energy storage provided by the inductors, the ZSI should require less capacitance and smaller size compared with the traditional VSI. Similarly, when the two capacitors (C_1 and C_2) are small and approach zero, the Z-Source network reduces to two inductors (L_1 and L_2) in series and becomes a traditional CSI. Therefore, a traditional CSI's inductor requirements and physical size is the worst case requirement for the Z-Source network. Considering additional filtering and energy storage by the capacitors, the Z-Source network should require less inductance and smaller size compared with the traditional CSI.

V. Zsi fed IM drive And Vsi Fed IM Drive

In this paper, for the comparison of VSI and ZSI, two models are prepared in MATLAB/SIMULINK environment. ZSI fed IM drive model is based on simple boost control technique. Whereas, the VSI fed IM drive model is based on sinusoidal pulse width modulation (SPWM). All the traditional pulse width modulation (PWM) schemes can be used to control the ZSI and their theoretical input-output relationships still hold.

VI. CLOSE LOOP SPEED CONTROL OF INDUCTION MOTOR USING V/f

When accuracy in speed response is a concern, closed-loop speed control can be implemented with the constant V/f principle through the regulation of slip speed. A PI controller is employed to regulate the slip speed of the motor to keep the motor speed at its set value. A simplified block diagram of the V/f controlled induction motor is shown in Figure 5. The closed loop control by slip regulation of combined inverter & induction machine improves the dynamic performance. The speed loop error generates the slip speed command, ω_{sl}^* through the proportional-integral controller and limiter. The slip is added to the speed feedback signal, ω_r to generate the synchronous speed command, ω_s^* . The synchronous speed command generates the voltage command V_s through a Volts/Hz function generator.

The slip is added to the speed feedback signal, ω_r to generate the synchronous speed command, ω_s^* . The synchronous speed command generates the voltage command V_s through a Volts/Hz function generator.

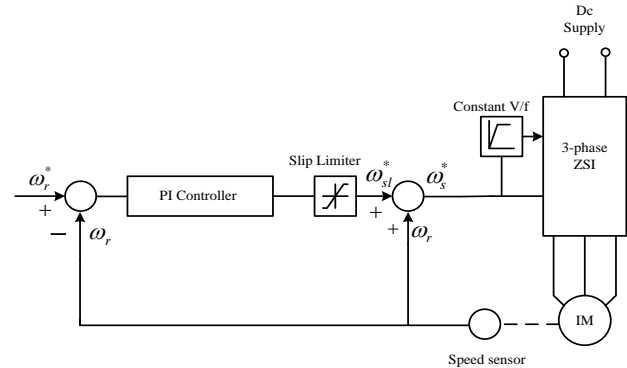

Figure 5: Closed-Loop Speed Control Scheme Utilizing V/f and Slip Regulation.

VII. Control Techniques For Vsi And Zsi

A. Simple Boost Control

The firing pulses generated using a simple boost control scheme for ZSI is shown in Figure 5. Three sinusoidal reference signals V_a , V_b and V_c and two constant DC voltages V_p and V_n are compared with the triangular carrier wave to generate the firing pulse with the shoot through state. The reference signals are phase displaced by 120 degrees and the amplitude of the two straight lines is equal to the peak amplitude of the reference wave. When the carrier wave is greater than the upper envelope V_p , or lower than the bottom envelope V_n , the circuit turns into shoot-through state. Otherwise it operates as traditional carrier based PWM.

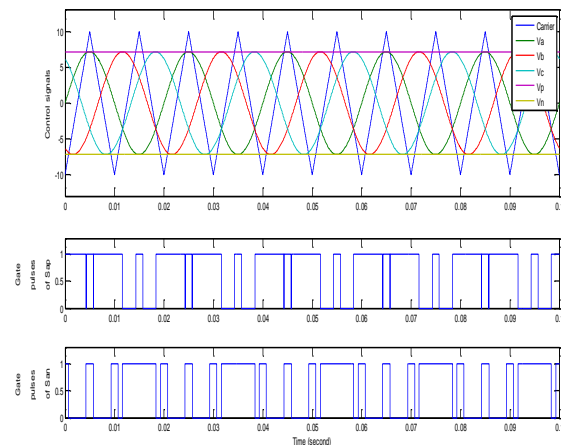

Figure 5. Simple Boost Control scheme for ZSI

VIII. SINUSOIDAL PWM

In three-phase SPWM, a triangular voltage waveform (carrier waveform) is compared with three sinusoidal control voltages (reference waveform), which are 120° out of phase with each other and the relative levels of the waveforms are used to control the switching of the devices in each phase leg of the inverter.

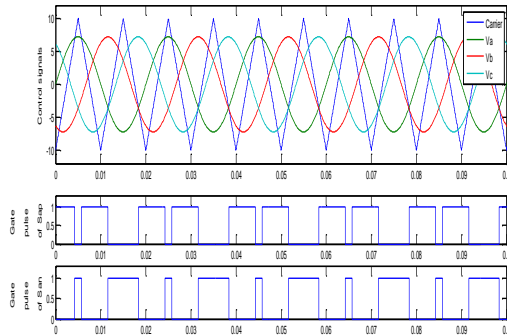

Figure 6. Traditional Sinusoidal PWM scheme

IX. SIMULATION RESULTS

In this section, the Simulink results obtained from the models of ZSI fed IM drive and VSI fed IM drive has been discussed. The different performance characteristics such as speed, torque, rotor current characteristics of ZSI fed IM drive and VSI fed IM drive are compared. For the time period 0-0.3 seconds, constant torque of value 0 N-m is applied to the motor drive of VSI and ZSI. For the time period of 0.3-0.42 seconds, the variable torque of the range between 15-30N-m is applied in the step of 0.02 seconds. Figure 7 and 8, shows the speed of VSI fed IM drive and ZSI fed IM Drive resp. From results, it is clear that the ZSI model gives better speed control than the VSI model. ZSI also provides less jerky motion at the starting of the motor as compared to VSI. When the variable torque is applied the change in the speed in VSI fed IM drive is greater and sudden as compared to ZSI fed IM drive.

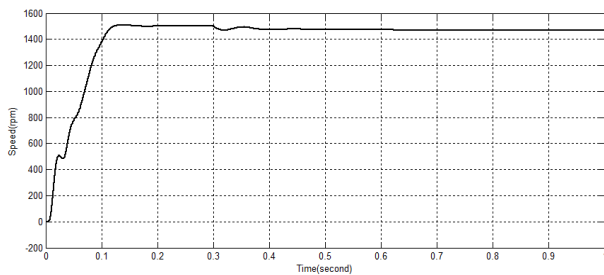

Figure 7. Speed of VSI fed IM Drive

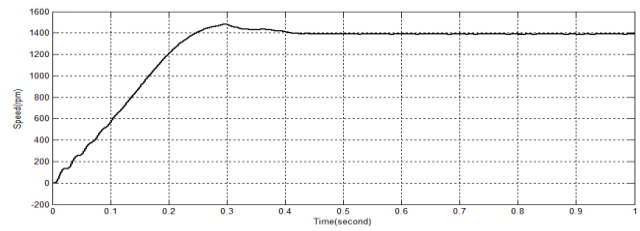

Figure 8. Speed of ZSI fed IM Drive

Figure 9 and 10 shows the rotor current for VSI fed and ZSI fed IM Drive resp. This clearly shows that with ZSI, settling time for rotor current is decreased as compared to VSI. It is also clearly seen that VSI has more ripple component as compared to ZSI.

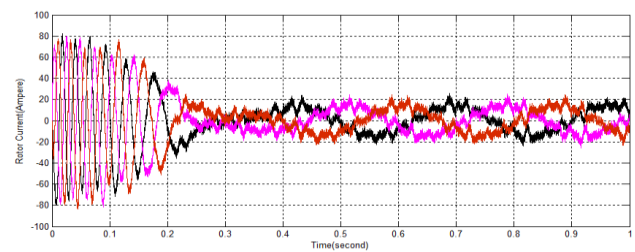

Figure 9. Rotor Current Of VSI

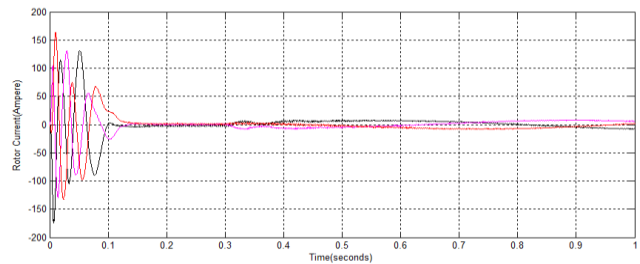

Figure 10. Rotor Current Of ZSI

Figure 11 and 12, shows the electromagnetic torque of VSI fed IM drive and ZSI fed IM Drive with variable load torque resp. From results, it is clear that the torque pulsations are more in the VSI fed IM drive as compared to ZSI. It is also noted that with the ZSI fed IM drive attain the load torque with less time as compared to VSI.

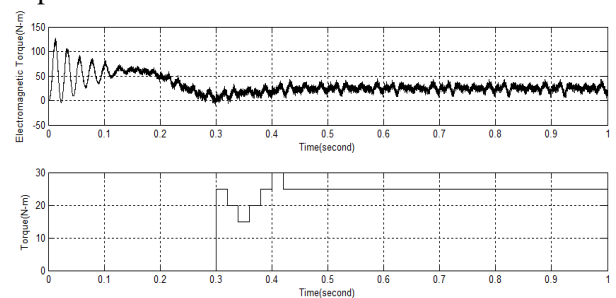

Figure 11. Electromagnetic Torque of VSI fed IM Drive

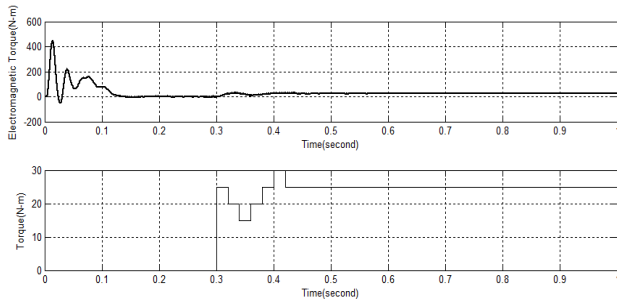

Figure 12. Electromagnetic Torque of ZSI fed IM Drive

X. CONCLUSION

This paper presents a comparative study on performance of the VSI and ZSI fed induction motor drive using MATLAB/Simulink. The performance characteristics of 3-phase induction motor such as, rotor speed, rotor current and electromagnetic torque was investigated on different load conditions. It is evident that the proposed scheme of three-phase IM drive with ZSI using simple boost control technique is faster and leads to a satisfactory operation in open loop systems as compared with VSI fed IM drive.

XI. REFERENCES

- [1]. F.Z.Peng, "Z-Source inverter,"IEEE Transaction Industry Applications, vol.39, pp.504-510, March/April 2003.
- [2]. F.Z.Peng,M.Shen, and Z.Qiang, "Maximum Boost Control of the Z-Source Inverter", IEEE Transactions on Power Electronics, vol.20, no.4, pp.833-838, July 2004.
- [3]. Fang Zheng Peng,Alan Joseph,JinWang,Miaosen Shen,Lihua Chen, Zhiguo Pan,Eduardo Ortiz-Rivera,Yi Huang, "Z-Source Inverter for Motor Drives"IEEE Transactions On Power Electronics,vol.20,no.4,pp.857-863,July 2005.
- [4]. T.Meenakshi,K.Rajambal,"Identification of an Effective Control Scheme for Z-Source Inverter", Asian Power Electronics Journal,vol.4,no.1,April 2010.
- [5]. D.Kumar, Z.Husain,"A Comparative Study of Z-Source Inverter Fed Three-Phase IM Drive with CSI and VSI fed IM, " International Journal of Power Electronics and Drive System (IJPEDS), vol.3, no.3, pp.259-270, September 2013.
- [6]. O.Ellabban,J.V.Mierlo and P.Lataire,"A new Closed Loop Speed Control of Induction Motor Fed by A High Performance Z-Source Inverter,"IEEE Electrical Power & Energy Conference,2010.
- [7]. B.Nayak and S.Dash, "Performance Analysis of Different Control Strategies in a Z-source Inverter, "ETASR - Engineering,Technology & Applied Science Research, Vol.3,pp.no.391-395,2013.
- [8]. B Husodo,S.M.Ayob,M.Anwari,Taufik,"Simulation of Modified Simple Boost Control for Z-Source Inverter,"International Journal of Automation and Power Engineering (IJAPE), Vol.2,Issue 4,May 2013.
- [9]. B.Singh,SP Singh,J Singh,M.Naim,"Performance evaluation of three phase induction motor drive fed from z-source inverter,"International Journal on Computer Science and Engineering (IJCSE), 2011.
- [10]. Jaswant Singh, "Transient Analysis of Z-Source Inverter Fed Three-Phase Induction Motor Drive by Using PWM Technique,"International Electrical Engineering Journal (IEEJ), vol.4, pp.no.856-863, 2013.
- [11]. S.Thangaprakash, A.Krishnan," Comparative evaluation of modified pulse width modulation schemes of Z-source inverter for various applications and demands,"International Journal of Engineering, Science and Technology, vol.2, no.1, pp.no.103-115,2010.