

Automatic Clamping, Embossing and Ejecting using PLC

¹Vannurwamy K, ²Jithendra Naik S

¹M.Tech Student, CAD/CAM, Department of Mechanical Engineering, PVKK Institute of Technology, Ananthapuramu, Andhra Pradesh, India

²Associate Professor, Department of Mechanical Engineering, PVKK Institute of Technology, Ananthapuramu, Andhra Pradesh, India

ABSTRACT

The aim of this paper is to evaluate the advantages of low cost industrial automation such as repeatability tighter quality control waste reduction and integration with business system increased productivity and reduction of labor in the small scale sector the application of low cost automation (LCA) particularly in small scale industries with simple uses of devices like pneumatic hydraulic actuators with electrical control to the exist conventional methods will make the automation at low cost to yield higher productivity this paper was taken up with a view to improve the present system of bottle filling, capping and Embossing process with low cost. LCA may step by step increase our technology rather than depending on foreign technology and productivity even in moderate and small factories and industries.

Keywords : Low Cost Automation(LCA), Function Block Diagram (FBD),Ladder Diagram (LD), Structured Text (ST; Similar to the Pascal Programming Language), Instruction List (IL; similar to Assembly Language) and Sequential Function Chart (SFC)

I. INTRODUCTION

The electro-pneumatic action is a control system for pipe organs, whereby air pressure, controlled by an electric current and operated by the keys of an organ console, opens and closes valves within wind chests, allowing the pipes to speak. This system also allows the console to be physically detached from the organ itself. The only connection was via an electrical cable from the console to the relay, with some early organ consoles utilizing a separate wind supply to operate combination pistons.



Fig. 1 Pneumatic Cylinders

A. Electro Pneumatic Operation

When an organ key is depressed, an electric circuit is completed by means of a switch connected to that key. This causes a low-voltage current to flow through a cable to the wind chest, upon which a rank or multiple ranks of pipes are set. Within the chest, a small electro-magnet associated with the key that is pressed becomes energized. This causes a very small valve to open. This, in turn, allows wind pressure to

activate a bellows or "pneumatic" which operates a larger valve. This valve causes a change of air pressure within a channel that leads to all pipes of that note. A separate "stop action" system is used to control the admittance of air or "wind" into the pipes of the rank or ranks selected by the organist's selection of stops, while other ranks are "stopped" from playing. The stop action can also be an electro-pneumatic action, or may be another type of action. This pneumatically assisted valve action is in contrast to a direct electric action in which each pipe's valve is opened directly by an electric solenoid which is attached to the valve.

B. Advantages

The console of an organ which uses either type of electric action is connected to the other mechanisms by an electrical cable. This makes it possible for the console to be placed in any desirable location. It also permits the console to be movable, or to be installed on a "lift", as was the practice with theater organs. While many consider tracker action organs to be more sensitive to the player's control, others find some tracker organs heavy to play and tubular-pneumatic organs to be sluggish, and so prefer electro-pneumatic or direct electric actions. An electro-pneumatic action requires less current to operate than a direct electric action. This causes less demand on switch contacts. An organ using electro-pneumatic action was more reliable in operation than early direct electric organs until improvements were made in direct electric components.

C. Disadvantages:

A disadvantage of an electro-pneumatic organ is its use of large quantities of thin perishable leather, usually lambskin. This requires an extensive "re-leathering" of the wind chests every twenty-five to forty years depending upon the quality of the material used, the atmospheric conditions and the use of the organ. Like tracker and tubular action, electro-pneumatic action is less flexible in operation than direct electric action,[citation needed] in which each

rank operates independently, allowing "unification", where each individual rank on a wind chest can be played at various octave ranges.

A drawback to older electric action organs was the large amount of wiring required for operation. With each stop tab and key being wired, the transmission cable could easily contain several hundred wires. The great number of wires required between the keyboards, the banks of relays and the organ itself, with each solenoid requiring its own signal wire, made the situation worse, especially if a wire was broken (this was particularly true with consoles located on lifts and/or turntables), which made tracing the break very difficult.

D. Sensors

A sensor is a converter that measures a physical quantity and converts it into a signal which can be read by an observer or by an (today mostly electronic) instrument. For example, a mercury-in-glass thermometer converts the measured temperature into expansion and contraction of a liquid which can be read on a calibrated glass tube. A thermocouple converts temperature to an output voltage which can be read by a voltmeter. For accuracy, most sensors are calibrated against known standards.

E. Proximity sensor

A proximity sensor often emits an electromagnetic field or a beam of electromagnetic radiation (infrared, for instance), and looks for changes in the field or return signal. The object being sensed is often referred to as the proximity sensor's target.



Fig.2 Proximity sensor

F. Capacitive proximity sensor

In electrical engineering, capacitive sensing is a technology, based on capacitive coupling that takes human body capacitance as input. Capacitive sensors detect anything that is conductive or has a dielectric different from that of air.

Mutual capacitive sensors have a capacitor at each intersection of each row and each column. A 12-by-16 array, for example, would have 192 independent capacitors. A voltage is applied to the rows or columns.. Mutual capacitance allows multi-touch operation where multiple fingers, palms or styli can be accurately tracked at the same time.

Self-capacitance sensors can have the same X-Y grid as mutual capacitance sensors, but the columns and rows operate independently. With self-capacitance, current senses the capacitive load of a finger on each column or row. This produces a stronger signal than mutual capacitance sensing, but it is unable to resolve accurately more than one finger, which results in "ghosting", or misplaced location sensing.

II. PROGRAMMABLE LOGIC CONTROL

A Programmable Logic Controller, PLC or Programmable Controller is a digital computer used for automation of electromechanical processes, such as control of machinery on factory assembly lines, amusement rides, or light fixtures. PLCs are used in many industries and machines. Unlike general-purpose computers, the PLC is designed for multiple inputs and output arrangements, extended temperature ranges, immunity to electrical noise, and resistance to vibration and impact. Programs to control machine operation are typically stored in battery-backed-up or non-volatile memory. A PLC is an example of a hard real-time system since output results must be produced in response to input conditions within a limited time, otherwise unintended operation will result.

A. Features

The main difference from other computers is that PLCs are armored for severe conditions (such as dust, moisture, heat, cold) and have the facility for extensive input/output (I/O) arrangements. These connect the PLC to sensors and actuators. PLCs read limit switches, analog process variables (such as temperature and pressure), and the positions of complex positioning systems. Some use machine vision. On the actuator side, PLCs operate electric motors, pneumatic or hydraulic cylinders, magnetic relays, solenoids, or analog outputs. The input/output arrangements may be built into a simple PLC, or the PLC may have external I/O modules attached to a computer network that plugs into the PLC.

B. Programming

PLC programs are typically written in a special application on a personal computer, and then downloaded by a direct-connection cable or over a network to the PLC. The program is stored in the PLC either in battery-backed-up RAM or some other non-volatile flash memory. Often, a single PLC can be programmed to replace thousands of relays.

Under the IEC 61131-3 standard, PLCs can be programmed using standards-based programming languages. A graphical programming notation called Sequential Function Charts is available on certain programmable controllers. Initially most PLCs utilized Ladder Logic Diagram Programming, a model which emulated electromechanical control panel devices (such as the contact and coils of relays) which PLCs replaced. This model remains common today. IEC 61131-3 currently defines five programming languages for programmable control systems: function block diagram (FBD), ladder diagram (LD), structured text (ST; similar to the Pascal programming language), instruction list (IL; similar to assembly language) and sequential function chart (SFC).. Even within the same product line of a

single manufacturer, different models may not be directly compatible.

C. PLC compared with other control systems

PLCs are well adapted to a range of automation tasks. These are typically industrial processes in manufacturing where the cost of developing and maintaining the automation system is high relative to the total cost of the automation, and where changes to the system would be expected during its operational life. PLCs contain input and output devices compatible with industrial pilot devices and controls; little electrical design is required, and the design problem centers on expressing the desired sequence of operations. PLC applications are typically highly customized systems, so the cost of a packaged PLC is low compared to the cost of a specific custom-built controller design. On the other hand, in the case of mass-produced goods, customized control systems are economical. This is due to the lower cost of the components, which can be optimally chosen instead of a "generic" solution, and where the non-recurring engineering charges are spread over thousands or millions of units.

For high volume or very simple fixed automation tasks, different techniques are used. For example, a consumer dishwasher would be controlled by an electromechanical cam timer costing only a few dollars in production quantities. A microcontroller-based design would be appropriate where hundreds or thousands of units will be produced and so the development cost (design of power supplies, input/output hardware and necessary testing and certification) can be spread over many sales, and where the end-user would not need to alter the control. Automotive applications are an example; millions of units are built each year, and very few end-users alter the programming of these controllers. However, some specialty vehicles such as transit buses economically use PLCs instead of custom-designed controls, because the volumes are low and the development cost would be uneconomical.

Job may spoil due to human errors, and different sizes cannot be obtained without changing the Embossing ratio. Consumes lot of time for doing repeated multiple jobs, these all are the drawbacks. The main concept of this machine is to emboss over particular jobs repeatedly at different dimensions Sequence is maintained. As the machine contains Molding motor, the movement is controlled accurately. The mechanical transmission section is controlled with stepper motor, based on the embossing period.

D. Timers

The delay-on timer introduces a delay between the start of one event and the start of another. For example, when a start push button is pressed, the pneumatic cylinder extends, remains extended for 5 seconds and then returns.

E. Counters

A counter allows a number of occurrences of input signals to be counted. The counter is set to a preset number value and when this value of input pulses has been received, it will operate its contacts. A second input or software coil is provided to reset the current value of the counter to zero.

III. AUTOMATIC CLAMPING, EMBOSSING AND EJECTING USING PLC

A. AUTOMATIC CLAMPING:

The high quality of the products is resulting in increased clamping for endurance mechanical intensifying and locking units as well as Pneumatic and Electromechanical release units are complementing the product range.

B. EMBOSSING:

It refers to the creation of an impression of some kind of design, decoration, lettering (or) pattern on another surface like Paper, Cloth, Metal and even a leather, to make a relief. In regular printing and engraving. Embossing used for Aesthetic purposes as well as functional uses in industries. From embossing

name on credit cards to embossed braille books for the bling, embossing has a wide range of applications and uses.

C. EJECTING OF OBJECT:

The object whenever the production line process are completes that needs to be automatically ejection. And this should eject within less time as well as noise free.

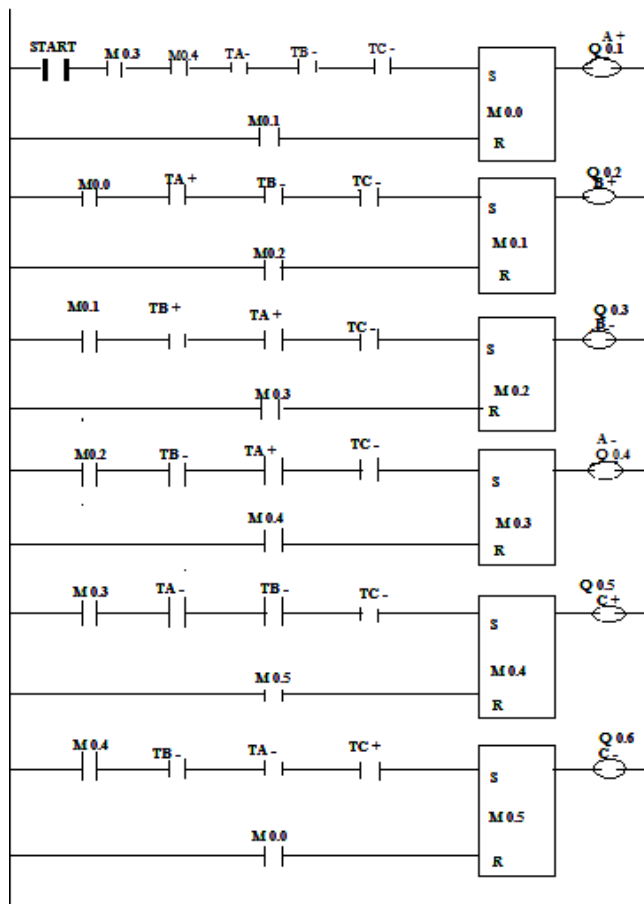

Fig.3 PLC LADDER DIAGRAM

TABLE 1 SEQUENCE OF OPERATION

A+	Clamping
A-	De clamping
B+	Forward motion for Embossing
B-	Backward motion after Embossing
C+	Ejecting the component
C-	Ejecting the component and Feedback to Input

TABLE 2 COST ANALYSIS

Name	Quantity	Price per unit (INR)	Total units price (INR)
Programmable logic controller	1	10000	10000
Double acting cylinder	4	1500	6000
Sensors	5	450	2250
Air filter regulator	1	1000	1000
Connecting wires and pipes	Miscellaneous	2000	2000
Relay circuit	2	600	1200
Single acting cylinder	2	1000	2000
3/2 solenoid control valve	2	300	600
Proximate sensors	12	400	4800
Driver motor	2	25000	50000
Driver frame and platform	2	500	1000
Fabrication	Miscellaneous	4000	4000
Air compressor	1	15000	15000
Total Cost			54850

TABLE 3 ESTIMATED RECOVERY PERIOD

Name	Cost (INR)
Total investment (without taxes)	4000
Number of bottles filed per day manually	400
Number of bottles filled per day automatically	1200
Profit per piece	1.80 INR
Increased profit per month (assuming 25 working days)	800 X 25=20000
Amount saved on labor per month	8000
Total profit per month	28000

TABLE 4 EXPENDITURE CHARGES

Name	Cost (INR)
Maintenance	2000
Total expenditure per month	6000
Net profit per month	28000-7000=21000
D.F(Depreciation factor)	0.15

By using SIEMENS STEP 7.0 PLC Pneumatic simulation software by choosing the required components from the components library and the drawn circuit is After drawing the circuit press the simulation button and circuit is ready for simulation then press the start button the embossing process starts, when the sensors are activated assigned operation is done.

1. Estimated recovery period

Table 3 indicates the estimated recovery period for the investment on the product design.

2. Increased expenditure

Table 4 indicates the estimated increase in the expenditure for up-gradation from manual to automatic process.

Payback period = $\frac{\text{total investment}}{\text{Net profit X}(1-D.F)}$

= $\frac{54850}{(21000 \times 1 - 0.15)}$

= 3 months 2 days

III. CONCLUSION

The experimental result shown and tested as per the basic requirements of any beverage or food process industry is a low cost automation process technique. A sequence for the given operation has been performed by using pneumatic drives as per the developed circuit. PLC program has been tested thoroughly for the sequence of operation and it is fed to the system. Automation of industries has many advantages, but it must never be regarded as an end itself. The main consideration is recovery of invested capital. Hence a good understanding of the concept of automation techniques is very essential. The application of LCA, particularly in small scale industries with the usage of simple devices like pneumatic and hydraulic actuators with electrical control to the existing conventional methods will make the automation at low cost to yield higher productivity for stability and growth of economy of the nation.

IV. ACKNOWLEDGEMENT

We successfully completed this project under the guidance of Mr. Mohanachari Jillellavadla Asst Professor, Department of Mechanical Engineering & Naveen Kumar Asst professor, Dept of ECE, Gates Institute of technology, Gooty, Ananthapuramu, Andhra Pradesh, India & We specially thank Shri

Krishna Swami, Director –Central Institute Of Tool Design, Balanagar, Hyderabad for permitting us to carry out the project work and allowing us to utilize the equipment and software to obtain the expected results.

V. REFERENCES

- [1]. Jhon W Webb, Ronald A Resis, 2002, PLC Principles and Applications, Prentice Hall's, "Chap 5, 9 & 28"
- [2]. Henry Ward Beecher, 2nd Edition "Introduction To Plc Programming and Implementation From Relay Logic To Plc Logic Industrial Text & Video, "Chap 9 & 13" [3] Hugh Jack, 2005 Automating Manufacturing Systems With PLCs, "Chap 3, 4, 5, 9 & 24" [4] N Dinesh Kumar And CH V B Aditya Kumar "Automatic Painting Process Using Pneumatics Through Plc" Journal Of Instrument Society Of India, Isoi, Volume 41 Book 2.
- [3]. P Chevtsov, S. Higgins, S. Schaffner and D. Seidman, "PLC Support Software at Jefferson Lab," Jefferson Lab, Newport News, 2002
- [4]. IJRMET Vol5 Issue 2 Further Expansion Automatic clamp embossing and ejecting PLC, ladder diagram has been solved in other way.