

# Design and Simulation of Solar Car

Mohd Yousuf Ahmed<sup>1</sup>, Appam Nihar<sup>2</sup>, Mohd Nayeemuddin<sup>3</sup>, Mohammed Ahmed<sup>4</sup>, Md Abdullah<sup>5</sup>

<sup>1</sup>Assistant Professor, Mechanical Department, Lords Institute of Engineering and Technology, Hyderabad, Telangana, India

<sup>2</sup>Assistant Professor, Mechanical Department, Lords Institute of Engineering and Technology, Hyderabad, Telangana, India

<sup>3,4,5</sup>Research Scholar, Mechanical Department, Lords Institute of Engineering and Technology, Hyderabad, Telangana, India

## ABSTRACT

This work, focused on an idea about solar car technology which solves the major problem of fuel and pollution in present days. Determine how feasible widespread change to solar car's would be in future with all information taken into account, concluded that solar cars have several advantages as energy efficient, low pollution. In the present work a complete drawing and drafting of solar car have been prepared using Solid works software. After complete analysis of this drawing by using ANSYS 13.0 it is find out bear capability of load, stress, and strain of front & rear collision of car frame. A completed data are analyzed to examine the technical aspects of the solar car technology. Overall, solar technology has a lot of potential in the distant future, but as for right now they are not a significant applied over today's internal combustion engine.

**Keywords :** Solar Car, Pollution ,Energy Efficient , Feasible Widespread, Internal Combustion Engine

## I. INTRODUCTION

There is an urgent need to stop subsidizing the Fossil fuel Industry, Dramatically reduce wasted energy and significantly shift our power supplies from oil, coal, and gas to wind, solar renewable resources. The main purpose of our project is to initiate research and development in transportation sector with the help of solar electric vehicle We aim to build & help automobile to use renewable resources .our focus is to develop interest among the engineering students towards alternative power sources which is going to fuel the transportation of future. We aim to design and fabricate a single seated solar powered vehicle without compromising the driver safety and ride quality. The main purpose of the project is to introduce the market with solar powered vehicles our aim is to promote and celebrate educational excellence and engineering creativity fueled by the spirit of friendly competition and team work. This helps to promote creative integration of technical and scientific expertise across the range of exciting disciplines. Our Objective is to To provide an enclosure around the driver in order to it into electricity, and are usually installed on the exteriors of the car. Looking at the above mentioned

protect him from any accidents. Like solar-powered homes, solar cars harness energy from the sun by converting it into electricity. This electricity fuels the battery that runs the car's motor. Instead of using a battery, some solar cars direct the power straight to an electric motor. Solar cars have some key benefits. Their solar panels work silently so they don't add to the noise pollution already on the road. Solar panels don't create greenhouse gases, as gasoline engines do. Most importantly, solar energy is free, widely available, and grants the solar car driver complete independence from foreign oil. Solar cars combine technology found in the aerospace, bicycle, alternative energy and automotive industries. The design of a solar powered car is limited by the necessity of getting lots of energy from the sun and storing that energy in batteries. Almost all solar cars ever built have been for the purpose of solar car races. One of the chief benefits is its eco-friendliness. These automobiles work on the same principles as any building powered by solar panels. Photovoltaic cells are special cells that are made up of semiconductors and are highly efficient in absorbing light. These cells harvest the solar energy and convert advantages, there is no doubt about solar powered vehicles being the next big thing of the future.

Moreover, not only during the day, solar energy engineers are working on ways to enhance the mileage such a vehicle can offer, by manufacturing a sun powered top that gives power to the motor while the daylight is plenteous, but ensures its optimum performance even when the sun goes down.

## II. METHODS AND MATERIAL

A. **Chasis** : Chassis is the French term which was initially used to denote the frame or main structure of vehicle. Chassis include all the major units necessary to propel the vehicle, directs its motion or stop it and allow it to run smoothly over uneven surfaces. It is also called as carrying unit. We used the Roll Cage chassis in our car . We have analyzed our roll cage using ANSYS and studied the maximum stress induced in it. We got the maximum stress value as 157MPa..According to our survey we came to the conclusion that ASTM 106 grade B can meet our requirements.

**Table I** : Material Properties

Properties	Metric
Material	Mild steel
Ultimate tensile strength (MPa)	400
Yield strength (MPa)	250
Modulus of elasticity (GPa)	200
Poisson's ratio	0.303
Outer diameter (mm)	25.4
Thickness (mm)	2
Mass density (kg/m <sup>3</sup> )	7850

### B. Design Considerations:

Weight of the chassis is as low as possible. The design allow a driver egress of 5 seconds. The driver have a vision of 160 degrees with 100 degrees on either side. The design of the chassis was modeled using solid works software.

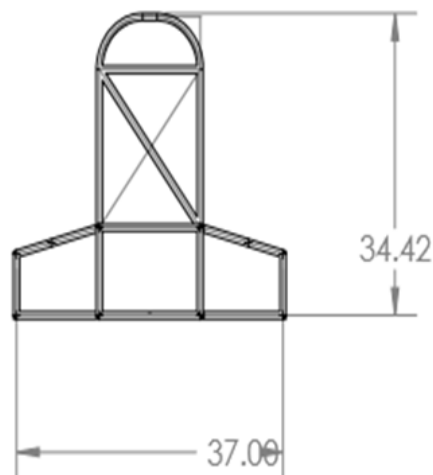

**Figure 1.** Front view of Chassy in inches

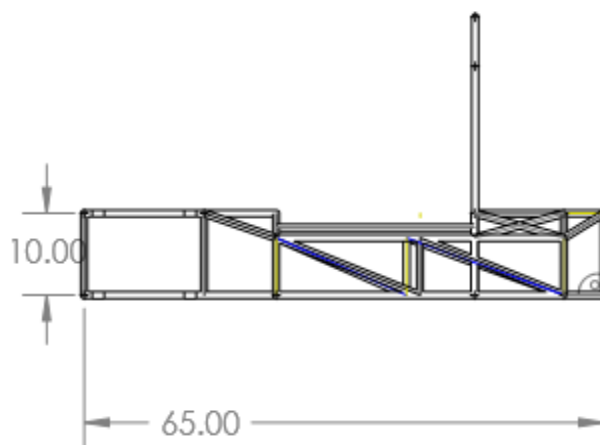

**Figure 2.** Side View of Chassy In Inches

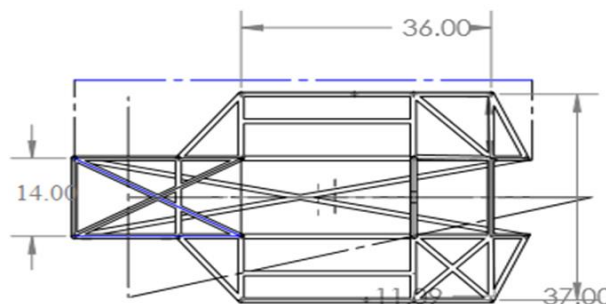

**Figure 3.** Top view of Chassy in inches.

### C. Simulation of vehicle frame

The analysis of the chassis was done by ANSYS software.

**Table II** : Units Used

Unit system	SI(MKS)
Length/displacement	Meter (m)
Temperature	Kelvin (K)
Angular velocity	Rad/sec
Pressure/stress	N/m <sup>2</sup>

## D. Static Loading

It is the load acting on the chassis due to its own weight when the vehicle is in static condition

Mass of driver = 60 kg

Self-weight of chassis = 23 kg

Mass of batteries = 16.3 kg

Mass of solar panel and others = 25 kg

Mass of motor = 5 kg

Mass of gear box = 11 kg

Total mass = 110 kg

Vertical force including gravity =  $110 \times 10 = 1100\text{N}$

Result: Static structural analysis

Applying load (4g)

## E. Calculation of g-forces

One g can be calculated by

$1g = \text{Weight} \times 10 = 110 \times 10 = 1100\text{N}$

To calculate 4g ( $1g \times 4$ ) =  $1100 \times 4 = 4400\text{N}$

All the calculations were done with the help of readings given by the software analysis.

## III. RESULTS AND DISCUSSION

### A. Front Impact Test

Front impact force is applied on rear suspension mounting point which is considered as a fixed point load intern which applies on the front portion of the chassis. Load is applied on front which is equal to 4 times of mass of the vehicle.

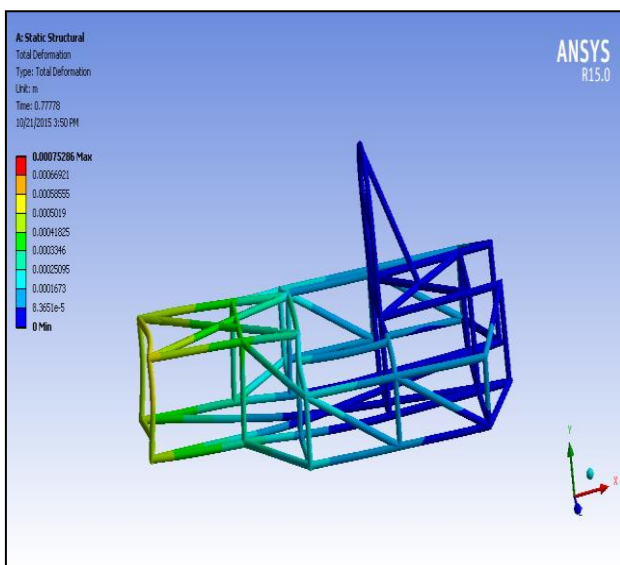

Figure 4. Total Deformation

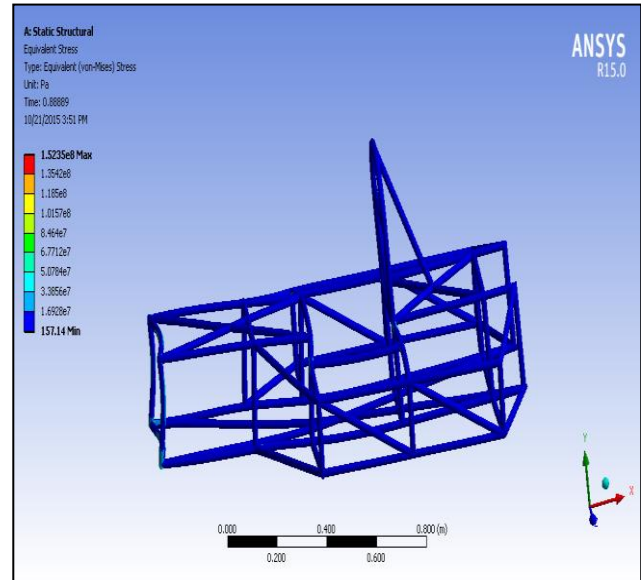

Figure 5. Equivalent Stress

Table III. Front impact parameters

Type of loading	Front impact test
Load(N)	4400
Equi-Stress (MPa)	152
Max. displacement(mm)	0.752
F.O.S	3.9

### B. Rear impact Test

Rear impact force applied as front suspensions mounting points is considered as a fixed point load is applied on the rear portion of the chassis. Load is applied on rear 4 times the mass of the vehicle.

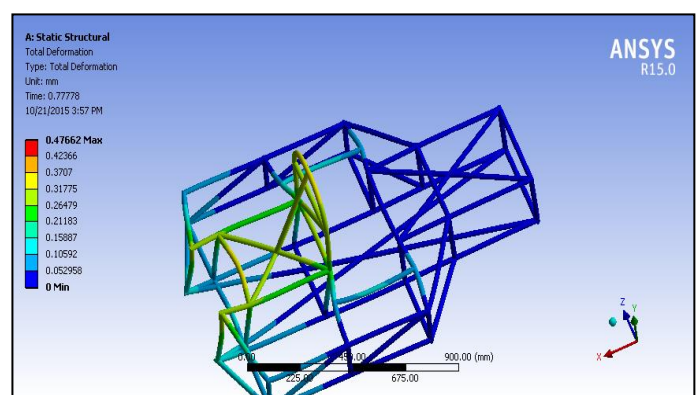

Figure 6. Total Deformation

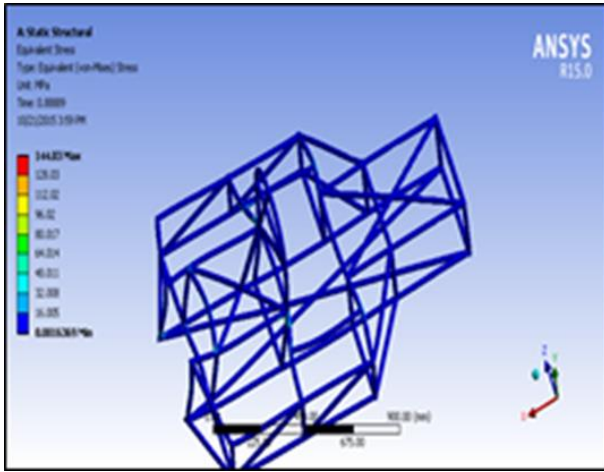

Figure 7. Equivalent Stress

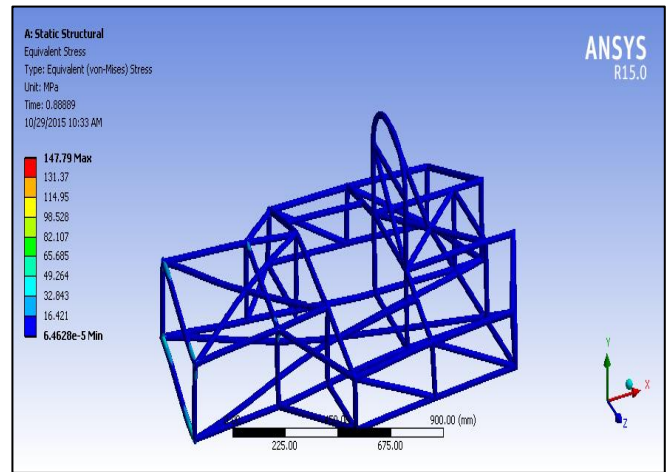

Figure 9. Equivalent stress (Von Mises).

Table IV. Rare Impact Parameters

TYPE OF LOADING	REAR IMPACT TEST
LOAD(N)	4400
EQUI.STRESS(MPa)	144
MAX. DISPLACEMENT(mm)	0.47
F.O.S	3.9

Table V: Torsion Test Parameters

TYPE OF LOADING	TORSION TEST
LOAD(N)	1650
EQUI. STRESS(MPa)	147.79
MAX. DISPLACEMENT(mm)	0.42475
F.O.S	1.5

### C. Torsion Test

Here the trailing arm suspension mount points are fixed and opposite forces are applied on the front two suspension mount points. Force on each joint  $F=450\text{N}$ . As the total weight of vehicle is  $110\text{kg}$  and Weight distribution is  $60:40$  so calculating The  $40\%$  and  $60\%$  of the weight that is  $45\text{ kg}$  and  $65\text{ kg}$  respectively .so the weight on single front tire will be  $45/2=22.5\text{kg}$  which is the force of  $225\text{ N}$ . Weight on the rear wheel =  $640.8\text{ N}$  So we can take a force of  $450\text{ N}$  assuming extreme conditions.

### D. Final CAD geometry

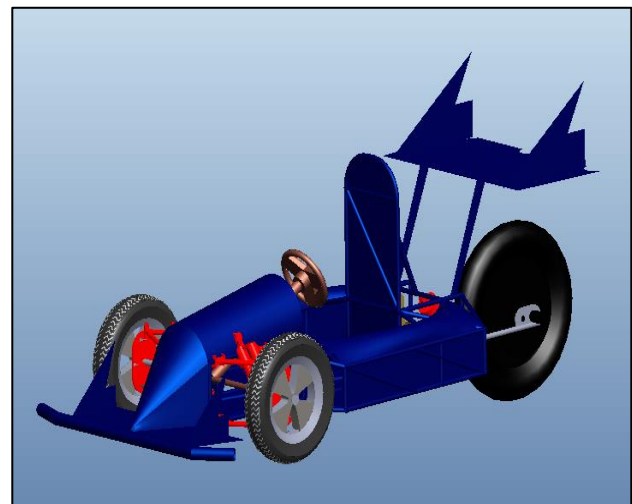

Figure 10. Isometric view of vehicle.

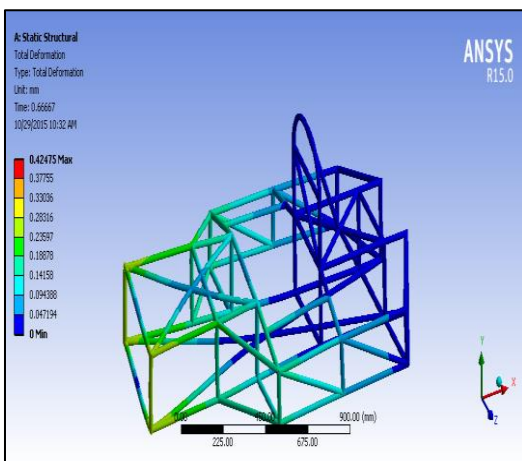
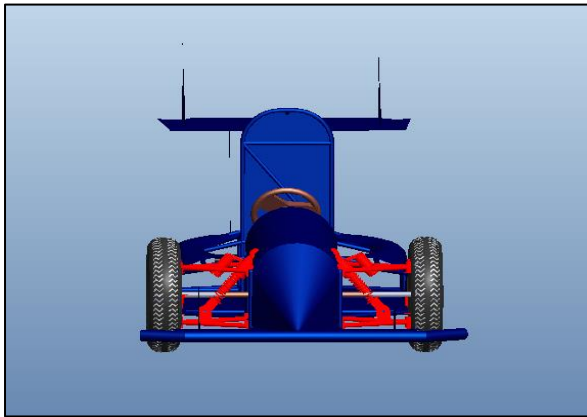
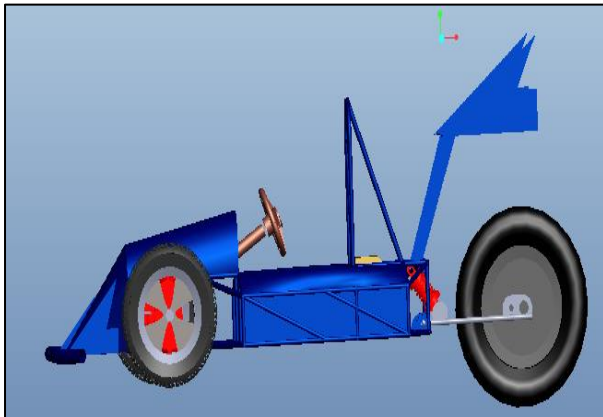

Figure 8. Total deformation.



**Figure 11.** Front View



**Figure 12.** Side view of the vehicle

#### IV. CONCLUSION

Solar vehicle is the best pollution free method. Solar vehicles do have some disadvantages like small speed range, continuous running depending upon the climatic conditions. But these disadvantages can be easily overcome. This multi charging vehicle can charge itself from both solar and electric power. During sunless condition, When the battery of the vehicle is fully charged it can run continuously at an average speed of 45km/h when the batteries are fully charged. A good feature of the proposed configuration is making a Solar/Electric vehicle and this vehicle can also be made as a hybrid vehicle by doing necessary operations. After the discussions and lots of feedbacks, in this series-parallel hybrid system is selected and to run this technology successfully, the solar energy is utilized in the maximum way with the help of calculations and as that the panel had been selected. From the panel used and the motor has powered, the backup source for the motor power is calculated. Finally, battery and controller are used. As a result of that the air and noise pollution would be reduced up to 30% in urban areas. The fuel could be used very effectively and the city's speed limit would be

maintained to a great extent. The accidents could be avoided.

#### V. REFERENCES

- [1]. Arsie, I., Rizzo, G., and Sorrentino, M., "Optimal Design and Dynamic Simulation of a Hybrid Solar Vehicle," SAE Technical Paper 2006-01-2997, 2006, doi:10.4271/2006-01-2997
- [2]. Rizzo, G. (2010), Automotive Applications of Solar Energy, IFAC Symposium Advances in Automotive Control, July 12 - 14 2010, Munich, Germany.
- [3]. M. W. Daniels and P. R. Kumar, "The optimal use of the solar power Automobile," Control Systems Magazine, IEEE, vol. 19, no. 3, 2005
- [4]. H. Shimizu, J. Harada, C. Bland, K. Kawakami, and L. Chan, "Advanced concepts in electric vehicle design," IEEE Transactions on Industrial Electronics, vol. 44, no. 1, pp. 14–18, 1997
- [5]. Yogesh Sunil Wamborikar, Abhay Sinha "Solar powered vehicle", WCECES Paper 2010
- [6]. H. Shimizu, J. Harada, C. Bland, K. Kawakami, and L. Chan, "Advanced concepts in electric vehicle design," IEEE Transactions on Industrial Electronics, vol. 44, no. 1, pp. 14–18, 1997.