

# Z Source Inverter for Three-Phase Induction Motor

Suresh Veer<sup>1</sup>, Rajat Ganjre<sup>2</sup>, Aishwary Kumbhalkar<sup>3</sup>, Sakshi Harne<sup>4</sup>, C. J. Sharma<sup>5</sup>

<sup>1,2,3,4</sup>Students, Dept. of Electrical Engineering, K.D.K.C.E, Nagpur, Maharashtra, India

<sup>5</sup>Professor, Dept. of Electrical Engineering, K.D.K.C.E, Nagpur, Maharashtra, India

sureshveer54@gmail.com<sup>1</sup>, rajatganjare@gmail.com<sup>2</sup>, aishwarykumbhalkar470@gmail.com<sup>3</sup>, sakshiharne34@gmail.com<sup>4</sup>,  
 chandar\_sharma75@gmail.com<sup>5</sup>

## ABSTRACT

This paper present the impedance source inverter for adjustable speed drive (ASD). Utilization of ZSI in industrial applications greatly increases the reliability by allowing only lower inrush current; lower harmonic injection and high immunity to EMI noises. Z Source Inverter can overcome this limitation, with the use of impedance source network. The impedance network connected between rectifier and inverter circuit, act as storage during input voltage, higher than required voltage and provide string voltage during input voltage is less than required voltage. By controlling shoot through duty cycle impedance source can be produce required ac voltage even greater than line voltage. As a result this impedance source system, provides, capability during voltage sag and swell, reduce harmonic, improve power factor and reliability, and extent the output voltage, analysis simulation and experimental result can be analyzed.

**Keywords:** Line Harmonics, Motor Drives, Voltage Sags, Z-Source Inverter

## I. INTRODUCTION

There are two traditional converter existing: voltage source converter (voltage kept constant / voltage fed) & current source converter (current kept constant / current fed).The voltage source converter has larger application than current source converter. Figure 1 shows the conventional 3 $\phi$  voltage source converter.

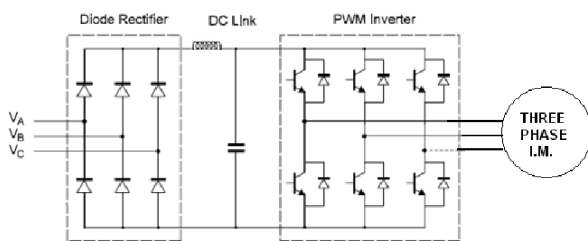

**Figure 1.** Conventional 3 $\phi$  Voltage Source Converter

For designing the inverter first we have to convert an AC voltage to DC voltage because the input require to an inverter is DC voltage. The AC voltage is converted into a DC by using Diode rectifier circuit. The DC voltage is passed from inductor and capacitor, which is act as a filter device. When an AC is converted to an DC then DC voltage is roughly equal to 1.35 times of AC voltage. The inverter circuit is step down converter that can only produces an limited AC voltage is quite below the input voltage.

For example, if we convert an 3 $\phi$  440 volt AC to DC voltage, then the DC voltage from an rectifier circuit is equal to 1.35 times i.e. 590 volts. This DC voltage is converted into an AC voltage by using an conventional inverter circuit, which gives an output approximately 420 volts. If this lower voltage is given to the 3 phase motor drive , during an light load condition the motor work efficiently but for heavy load condition the motor requires larger voltage at the

starting but it required is not given by the traditional inverter circuit hence, the motor draws more inrush current and harmonics because of that the efficiency of motor get reduces and power factor affected.

Performing and Reliability are compromised by the conventional voltage source because,

I) Misgating from EMI (Electro Magnetic Interference) can cause a shoot through that increase the chances of failure of inverter .

II) The dead time is needed to avoid the shoot through that also increase losses in an inverter.

The output of conventional converter is shown in following Figure below,

Waveform of voltage:

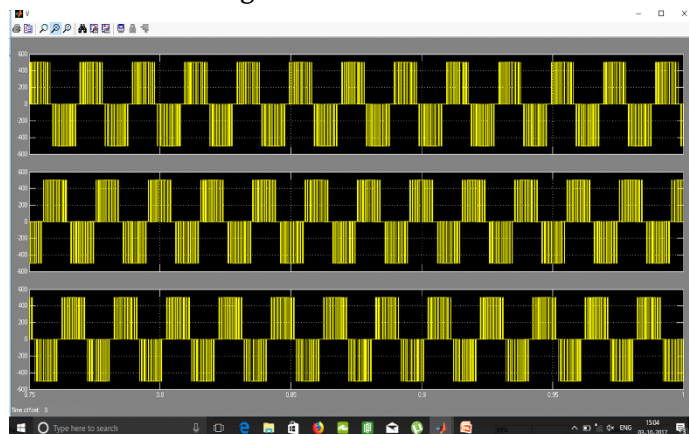

Figure 2. Output Voltage

Waveform of Current:

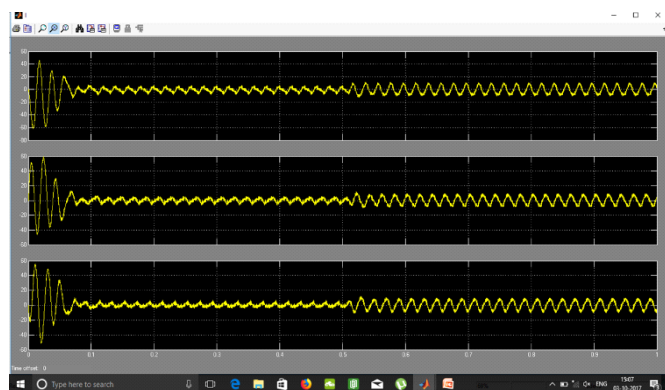

Figure 3. Output Current

Waveform Of Power:



Figure 4. Output Power

## II. Z-SOURCE NETWORK

The Z-source network is logically design which has a unique impedance network to connect both the circuits i.e. main supply to power supply, it can produce any desire output ac voltage which can be greater than the input dc voltage by controlling the shoot-through duty cycle.

The Z-Source network consists of two inductors ( $L1&L2$ ) and capacitors ( $C1&C2$ ) connected in a triangular to provide an impedance source (Z-Source) coupling between the inverter and DC source. Thus, the DC source connected to the Z-Source network can be a voltage or current source. Therefore, the DC source can be a battery, diode rectifier, thyristor converter, an inductor, a capacitor or any combination of these can be used. Another advantage of this inverter over a traditional inverter is that one can use a variable DC source such as fuel cell, Photovoltaic cell or a wind turbine. The in-rush current and harmonics in current can be reduced due to inductor used in Z-Source network.

The unique feature of the ZSI is that the output AC voltage can be any value between zero and infinity regardless of the input DC voltage. That is, the ZSI is a buck-boost inverter that has a wide range of

obtainable voltage. The traditional VSI cannot provide such feature.

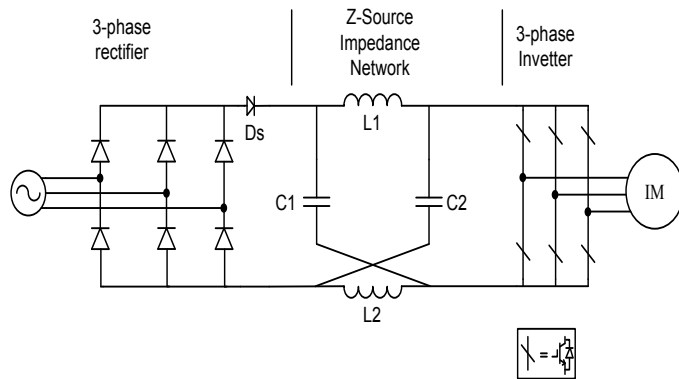

**Figure 5.** Z-source inverter

To describe the operating principle and control of the ZSI shown in Figure 1.4, let us briefly examine the ZSI structure. In Figure 1.4, the three-phase Z-Source inverter bridge has nine switching states unlike the traditional three-phase VSI that has eight. The traditional three-phase VSI has six active states when the DC voltage is impressed across the load and two zero states when the load terminals are shorted through either the lower or upper three devices. However, the three-phase Z-Source inverter bridge has one extra zero state when the load terminals are shorted through both the upper and lower devices of any one phase leg, or any two phase legs, or all three phase legs. This state is forbidden in the traditional VSI, because it would cause a shoot-through. We call this third zero state the shoot-through zero state, which can be generated by seven different ways: shoot-through via any one-phase leg, combinations of any two-phase legs, and all three-phase legs. The Z-Source network makes the shoot-through zero state possible. This shoot-through zero state provides the unique buck-boost feature to the inverter. During this state, energy is transferred from the capacitors to inductors, thereby giving rise to the voltage boost capability of the ZSI.

Figure shows the equivalent circuit of the ZSI shown in Figure 5, when viewed from the DC-link. The inverter bridge is equivalent to a short circuit when the inverter bridge is in the shoot-through zero state,

as shown in Figure 6 (a). Whereas inverter bridge is equivalent to open circuit when it is in one of the traditional zero states, as shown in Figure 2.1-(b). And the inverter bridge becomes an equivalent current source as shown in Figure 2-1(c) when in one of the six active states. Note that the inverter bridge can be also represented by a current source with zero value (i.e., an open circuit) when it is in one of the two traditional zero states. The three modes are used as listed below,

**Mode 1: Active state**

The inverter bridge is operating in one of the six traditional viewed from active vectors, thus acting as a current source and conduct the Z-source circuit. The diodes carry currents. Figure. 1.1(a) shows the circuit of this mode. In the traditional ASD system, the diode bridge may not conduct depending on the dc capacitor voltage level. However, and to the Z-source circuit always forces diodes conduct and carry the current difference between the inductor and inverter dc current as shown current in Figure. 1.1(a). Note that both inductors have an identical current value because of the circuit symmetry. This unique feature the line current conducting intervals, thus reducing harmonic current.

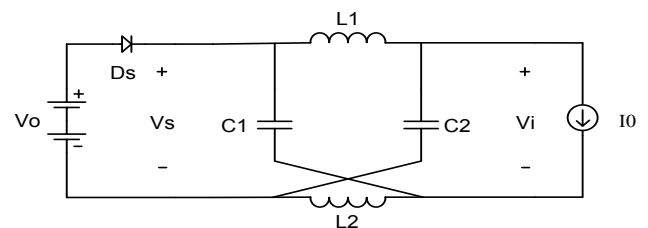
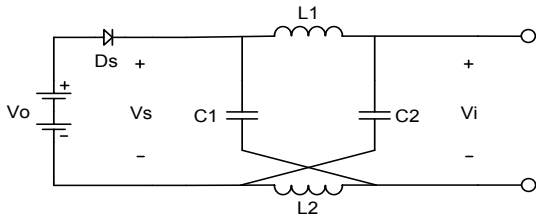

**Figure 6.** (a): when the inverter bridge is producing one of the six traditional active vectors

**Mode 2: Zero State**

The inverter bridge is operating in one of the two traditional zero vectors and shorting through either the upper or lower three devices, thus acting as an open circuit viewed from the Z-source and conduct and carry currents the circuit. (Figure. 2.1(b) shows the circuit for this mode). Again, under this conduct and

carry mode, the two diodes the inductor current, which contributes to the line current's harmonic reduction.



**Figure 6 (b):** When Inverter Bridge Is Producing One Of The Two Traditional Zero Vectors

**Mode 3: Shoot-through Mode**

In this the shoot through states both diodes are off, separating dc link from ac link. Figure 6. a and 7. b shows the equivalent circuit of ZSI when the diode is conducting state (Non- Shoot through mode) and the non-conducting state (Shoot through mode) respectively [8-11]. In shoot through mode as in Figure 1. 2. b., a diode placed at the input side is reverse biased and the capacitors charge the inductors and voltage across the inductor is:

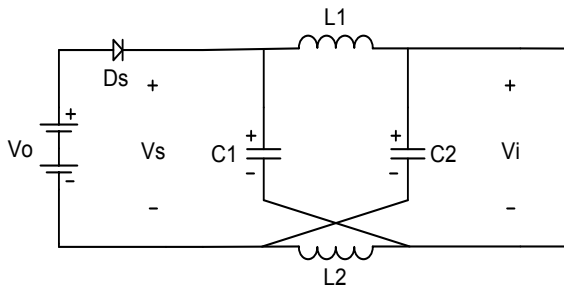

**Figure 6(c).** Shoot Through Mode

**III. SIMULATION AND EXPERIMENTAL VERIFICATION**

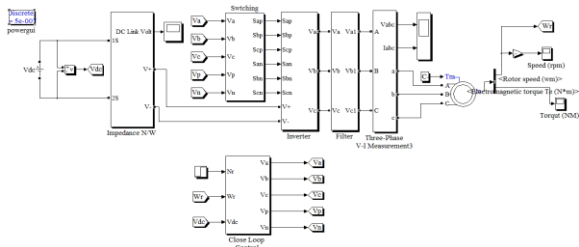

**Figure 7.** Simulation and Experimental Diagram

Simulation Parameter

S.No	Quantity	Value
------	----------	-------

1	Z-Source Impedance Value	$L1=L2=1\text{mH}$ and $C1=C2=1.3\mu\text{F}$
2	Input DC Voltage	400V
3	Carrier Wave Frequency	10KHZ
4	Cutoff Frequency of LC Filter	1KHZ
5	Induction Motor	4kW, 400V(LL), 50Hz, 1430RPM, 4 Pole
6	Load Torque	20Nm

Waveform of Output Voltage:

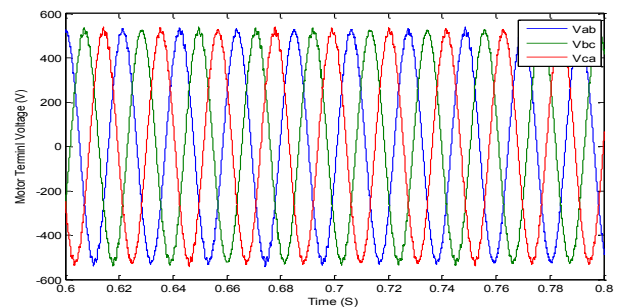

**Figure 8(a).** Output voltage waveform

Waveform of Output Torque:

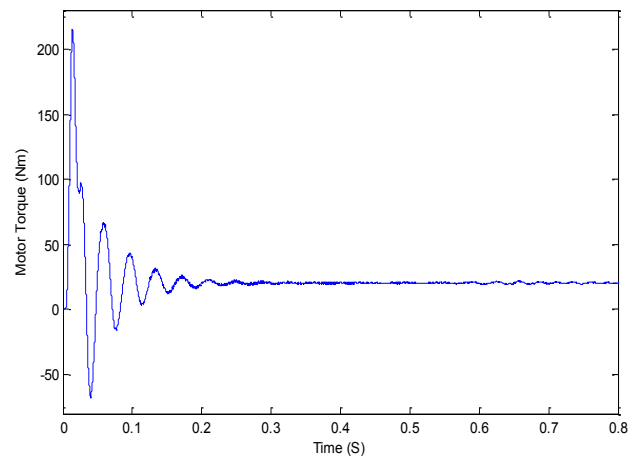

**Figure 8(b).** Output Torque Waveform

**IV. CONCLUSION**

This paper has presented a new ASD system based on the

Z-source inverter. The operating principle and analysis have been given. Simulation and experimental results verified the operation and

demonstrated the promising features. In summary, the Z-source inverter ASD system has several unique advantages that are very desirable for many ASD applications, it

- Can produce any desired output ac voltage, even greater than the line voltage;
- Provides ride-through during voltage sags without any additional circuits and energy storage;
- Minimizes the motor ratings to deliver a required power;
- Reduces in-rush and harmonic current.

## V. REFERENCES

- [1] H. G. Sarmiento and E. Estrada, "A voltage sag study in an industry with adjustable speed drives," *IEEE Ind. Applicat. Mag.*, vol. 2, no. , pp.16–19, 1996.
- [2] A. Van Zyl, R. Spee, A. Faveluke, and S. Bhowmik, "Voltage sag ridethrough for adjustable-speed drives with active rectifiers," *IEEE Trans.Ind. Applicat.*, vol. 34, no. 6, pp. 1270–1277, Nov./Dec. 1998.
- [3] A. von Jouanne, P. N. Enjeti, and B. Banerjee, "Assessment of ride through alternatives for adjustable-speed drives," *IEEE Trans. Ind. Applicat.*,vol. 35, no. 4, pp. 908–916, Jul./Aug. 1999.
- [4] Y. Kim and S. Sul, "A novel ride-through system for adjustable-speed drives using common-mode voltage," *IEEE Trans. Ind. Applicat.*, vol.37, no. 5, pp. 1373–1382, Sep./Oct. 2001.
- [5] J. L. Duran-Gomez, P. N. Enjeti, and A. von Jouanne, "An approach to achieve ride-through of an adjustable-speed drive with flyback converter modules power by super capacitors," *IEEE Trans. Ind. Applicat.*, vol. 38,no. 2, pp. 514–522, Mar./Apr. 2002.
- [6] K. Stockman *et al.*, "Bag the sags—Embedded solutions to protect textile process against voltage sags," *IEEE Ind. Applicat. Mag.*, vol. 10, no. 5, pp. 59–65, Sep./Oct. 2004.
- [7] F. Z. Peng, "Z-source inverter," *IEEE Trans. Ind. Applicat.*, vol. 39, no.2, pp. 504–510, Mar./Apr. 2003.
- [8] F. Z. Peng, M. Shen, and Z. Qian, "Maximum boost control of the z-source inverter," in *Proc. 39th IEEE Industry Applications Conf.*, vol.1, Oct. 2004.
- [9] M. Shen, J.Wang, A. Joseph, F. Z. Peng, L. M. Tolbert, and D. J. Adams,"Maximum constant boost control of the Z-source inverter," presented at the IEEE Industry Applications Soc. Annu. Meeting, 2004.
- [10] F. Z. Peng, X. Yuan, X. Fang, and Z. Qian, "Z-source inverter for adjustable speed drives," *IEEE Power Electron. Lett.*, vol. 1, no. 2, pp.