

# Static Stress Analysis on Adaptor Spool-Flange Assembly for Enhancement of Pressure Rating

MSSR Ravi Kiran<sup>1</sup>, D. Srinivas Chaitanya<sup>2</sup>

Mechanical Engineering Department, Sreenidhi Institute of Science and Technology, Yamnampet, Ghatkesar, Hyderabad, India

## ABSTRACT

Power plant and petroleum industries require huge number of piping networks to transfer fluid between different sections of the plant. Adaptor spool & adaptor flange assembly connects pipes as they are considered as simple and can be bolted to one another. Adaptor spools are imbedded into concrete walls during the construction. This thesis points out at spool flange & adaptor assembly design pertaining to petroleum industry. The assembly should be designed in such a way that it has to with-stand complex circumstances conditions such as continuous variations in pressure loads, temperature and flow variations. This will trigger some kind of uncertainty failures in the pipe network especially in spool flange adaptor assembly. Taking into account of pressure loads, the project modelled and analyzed the spool flange adaptor assembly. For this design study FEA approach with ANSYS is exhaustively used. With the simulation study the pressure rating of adaptor spool flange assembly is analysed. By modifying the geometry of elements of the assembly, the pressure rating is enhanced. This will help in increasing the life of pipe network in petroleum industry.

**Keywords :** Spool, Adaptor, Flange, ANSYS, FEA.

## I. INTRODUCTION

A flange is designed to connect sections of pipe or tube, to join the pipe or tube to an assembly such as a pressure vessel, valve or pump. Flanges are joined by bolting and sealing is completed with the use of gaskets and other sealing methods, and fixed to the piping system by welding or threading. Flanged joints sometimes involves an adaptor flange, which is a dismantling joint with one side a adaptor spool connection in accordance with the required flange standard and on the other an insertion socket for the pipe. Adaptor flanges are an expanded group of flange joint accessories that allow the mating of dissimilar flange types or flanged and non-flanged equipment. Flange adaptor will function as mechanical pipe joints in pipe networks to facilitate the removal of valves

and fittings without disturbing the pipelines and eradicate ground movement, expansion, contraction and angular misalignment of the pipeline. Adaptor flange provides a reliable, leak proof and quick method of joining plain ended, threaded pipes for the transmission of fluid and an easy access for cleaning, inspection or modification.

## II. DESIGN

**A. Adaptor spool :** It can be inferred from the figure that the component has two openings on the either sides of hub which face either sides when fixed between two sections. On to the right side we have 3-1/8" sized with pressure rating 34.47 MPA (5000 psi) and groove for gasket type RX35 is failing to operate a little

beyond its rated pressure. As to another side it is rated to 68.94 MPa (10000 psi) pressure with gasket BX154, under operation combined circumstances make the 10K psi safe but the other end it might end up creating hindrances and may fail through its life. Considering the above circumstances there arises a need to make the 5K psi side safe to certain level, such that it could resist the extra pressure operated other end. For situation of this kind we could find solutions for enhancement in following ways:

Design change.

Material change

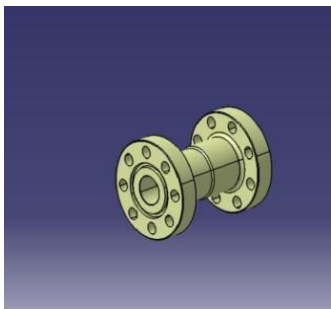

Figure 1: Adaptor spool

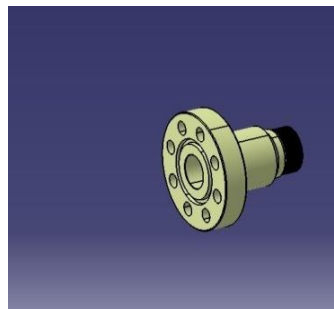

Figure 2: Adaptor flange

**B. Adaptor flange:** It can be inferred from the figure that the component has two openings on the either sides

of hub which face either sides when fixed between two sections. On to the left side we have 3-1/8” sized with pressure rating 34.47 MPa (5000 psi) and groove for gasket type RX35 is failing to operate a little beyond its rated pressure. Flange adaptors are themselves represented by a vast array of different types and they fall into two main categories. The first are flange-to-flange types, with the second being those used to join flanged and non-flanged equipment.

**C. Modelling and simulation:** For 3D analysis the of the assembly shown in figure.3 has been obtained from CATIA and assembled in CREO 3.0.

### III. FINITE ELEMENT ANALYSIS

#### A. Material properties:

Material properties are given in the Table 3.1

#### B. Boundary conditions:

Pressure, fixed supports. The so stated boundary conditions are represented in the figure 4.

**TABLE 1**

**MATERIAL PROPERTIES OF AISI 4130**

Density	7.85 g/cm <sup>3</sup>
Melting point	1432°C
Tensile strength, Ultimate	670Mpa
Tensile strength, Yield	435Mpa
Modulus of elasticity	200Gpa
Bulk modulus	140Gpa
Poisson's Ratio	0.29
Thermal conductivity	42.7W/m-K

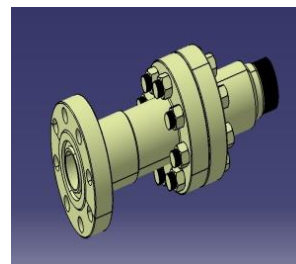

Figure 3 : 3D Model of assembly

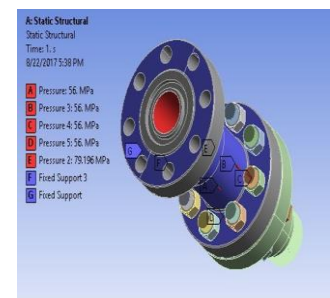

Figure 4: Applied boundary conditions

#### C. Meshing Model:

Assembly 3D model is meshed with tetrahedral elements.

#### D. FEM validation of assembly:

The validation of the assembly is done by comparing the von-mises stress values based upon yielding of assembly i.e. yield value of material.

**E. Design changes:**

From the existing pitch circle diameter i.e. 136.525mm, increased to 140.525mm.

From the existing seal ring width W=11.91mm, increased to 13.91mm.

Hence by making the above changes the effective area has been increased by 3481.512mm<sup>2</sup>.

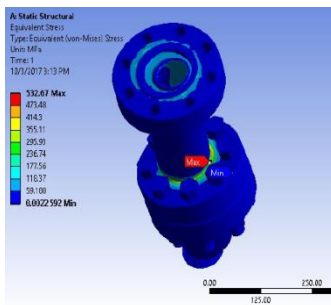

Figure 5: ANSYS result of von-mises stress

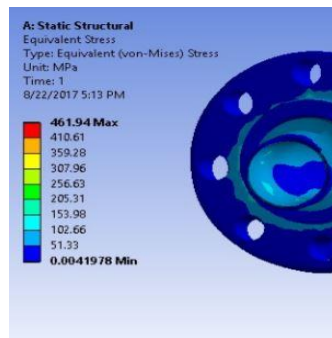

Figure 6: New design simulation.

**IV. OPTIMIZATION**

As stated earlier the 10K Psi side pressure reflects through to other side, which any how is more as per its rated 5K Psi range the opposite end. Which definitely becomes an hindrance and when simulated to a little higher pressure above 34.47Mpa i.e. 5000Psi Adaptor spool is yielding beyond its limits means failing to with stand.

Hence through optimization the effective area has been increased by 3481.512mm<sup>2</sup>, through these changes the component is able to with stand more pressure from 34.47Mpa to 51Mpa.

The following figure shows the stress values resulted to simulated conditions.

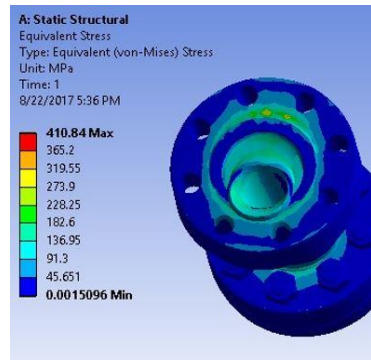

Figure 7 : Optimized design Von-mises stress result.

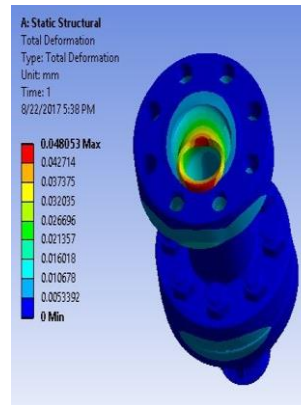

Figure 8 : Optimized design deformation result.

**V. CONCLUSIONS**

With the analysis of existing adaptor spool-flange assembly it is found that the assembly is safe upto fluid pressure of 34.47Mpa(5000 Psi) in the pipe line. In most of petro-chemical applications requires a pipe network generally subjected to pressure fluctuations from 4000Psi to 7000Psi.

SL.No	Allowable limiting stress(Yield)	Simulated stress
1	435Mpa	532.67Mpa

Simulation studies are carried out by increasing the dimensions PCD & ring width of gasket and the mating grooves of adaptor spool and flange by 3%. The results show that there is a substantial improvement of pressure rating of the assembly up to 51Mpa. The developmental steps used for modeling and analysis of adaptor spool-flange assembly will be helpful for further increase of pressure rating of assembly.

**VI. REFERENCES**

[1]. Abid M, Chattha J. A, Khan K. A, "Finite Element Analysis of a Gasketed Flange Joint Under Combined Internal Pressure and

- Thermal Transient Loading”, Proceedings of ASME PVP2007/Creep 8 Conference, 2007.
- [2]. P. M. Desai, B. C. Pathak, V. A. Patel and P. B. Rana, Design, Analysis and Optimization of Body Flange and Cover Flange Using Finite Element Analysis, International Research Journal of Mechanical Engineering and Technology (IRMET), 4(5), 81-87, 2013.
- [3]. Muhsen Al-Sannaa and AbdulmalikAlghamdi, “Two dimensional finite element analysis for large diameter steel flanges”, 6th Saudi Engineering conference (2002), Vol.5, pp. 397-408.
- [4]. Khan, A.M.; Chattha, K.A.; Study the performance of a flange joint using combined internal pressure and thermal loading, ASME PVP/ CREEP 8 conference, 2007, 1-7.
- [5]. M.Murlikrishna, M.S.Shunmugam And N.Siva Prasad, “A study of the sealing performance of bolted flanged joints with gaskets using finite element analysis”- International Journal of Pressure Vessels and Piping 84,2007,pp-349-357.
- [6]. M.Abid and D.H.Nash, “ A Parametric study of metal to metal contact flanges with optimised geometry for safe stress and no leak condition”- International Journal of Pressure vessels and Piping 81 , 2004, pp 67-74.

**Cite this article as :**

MSSR Ravi Kiran, D. Srinivas Chaitanya, "Static Stress Analysis on Adaptor Spool-Flange Assembly for Enhancement of Pressure Rating", International Journal of Scientific Research in Science, Engineering and Technology (IJSRSET), ISSN : 2456-3307, Volume 6 Issue 1, pp. 426-429, January-February 2019.

Available at doi :

<https://doi.org/10.32628/IJSRSET196175>

Journal URL : <http://ijsrset.com/IJSRSET196175>