

Smart Electricity Billing Using Node-MCU

D. V. N.Ananth¹, G. Joga Rao² Ch. Satish³, J. Shyam⁴, K.Santosh⁵, U.V.V.S.S.V.Prasad⁶, K. Ramya⁷

¹Assistant Professor, EEE Department, Raghu Institute of Technology, Visakhapatnam, Andhra Pradesh, India

²Associate Professor, EEE Department, Raghu Institute of Technology, Visakhapatnam, Andhra Pradesh, India

³⁻⁷B.Tech, EEE Department, Raghu Institute of Technology, Visakhapatnam, Andhra Pradesh, India

ABSTRACT

There are many problems in metering and billing processes like the going of meter reader to each customer meter to manually take the meter reading, the probability of the non-existence of the customers at their homes during that time, the lack of integrity and credibility of some of the meter readers, the safety and the outback areas represent a huge drawback cannot be neglected. In other hand, the in service classical energy meter type (induction type) suffers from well-known measuring errors. The above problems result in two significant points, waste of much money due to the large number of employees (meter readers) and the weakness in electricity management which results in lack in electric power. This project provides an excellent solution to the problems mentioned above where the system has been designed based on the use of energy smart meter to read electrical energy consumed to get an accurate reading. Then the energy reading is sent to the control centre in the electricity department based on GSM/SMS technology. The system in the electricity department receives readings and makes processing operations on them and extracts the bills that must be paid by the customer. The system also sends a message to the own customer mobile phone which contains the current bill, due bill, and total bill every two months have to be paid. In addition the system has the ability to print out a hard copy of the customer bill. Finally the proposed system has the ability of automatic power outage if the customer refrains or delays for certain time in paying the bills by means of an SMS.

Keywords: Energy Meter, Node-MCU, Current Sensor, Voltage Regulator

I. INTRODUCTION

The world is changing towards automatic wireless technologies, which prefer not only reducing human efforts but is helping in making systems automatic and efficient. A system is said to be intelligent when it can decide what to do without any instruction and can work automatically. An Electric or Energy meter measures the total electrical energy in units used by the appliances which consume electrical energy from the main power supply. Electromechanical and Electronic meter are two types of meter Available in the market to measure the unit consumption.

Electromechanical meters are commonly used in village areas, where the uses of modern technology are not as high as it is in cities. Electromechanical meters have become out of date nowadays.

Electronic meters replace electromechanical meters. This meter consists of LCD/LED to display the reading. Calibration Led is used on the meter which shows the units consumed. Manpower is required to read the meter and note down the reading. The reading on the meter is increasing which is used to generate the electricity bill. An IOT Based Smart Electricity Meter and billing System does the same

task without human efforts. IOT Based SEM system is controlled using Arduino Mega, which is a microcontroller board. The purpose behind choosing this board is its efficiency and memory. It is more efficient in terms of memory and GPIO. The data obtained is then sent to the cloud through the internet. Data obtained can be easily sent wirelessly over long distance without any noise disturbance using the internet. As the data is directly sent to the cloud there is no occurrence of range and distance problem and is highly accurate and efficient because of no human interference. Other wireless technologies such as Zigbee, Bluetooth etc. have limited range thus cannot be used over very long distances effectively. This project envisages the use internet and the concept of IOT by which the base station, as well as users, remain updated with the current consumed units, changing the present problems faced by the electricity board and the user. In the present billing system the distribution companies are unable to keep track of the changing maximum demand of consumers. The consumer is facing problems like receiving due bills for bills that have already been paid as well as poor reliability of electricity supply and quality even if bills are paid regularly. The remedy for all these problems is to keep track of the consumers load on timely basis, which will help to assure accurate billing, track maximum demand and to detect threshold value. These are all the features to be taken into account for designing an efficient energy billing system. The present project “IoT Based Smart



Fig.1 Energy Meter

Energy Meter” addresses the problems faced by both the consumers and the distribution companies. The paper mainly deals with smart energy meter, which utilizes the features of embedded systems i.e. combination of hardware and software in order to implement desired functionality. The paper discusses comparison of Arduino and other controllers, and the application of GSM and

Wi-Fi modems to introduce ‘Smart’ concept. With the use of GSM modem the consumer as well as service provider will get the used energy reading with the respective amount, Consumers will even get notification in the form text through GSM when they are about to reach their threshold value, that they have set. Also with the help of Wi-Fi modem the consumer can monitor his consumed reading and can set the threshold value through webpage. This system enables the electricity department to read the meter readings monthly without a person visiting each house. This can be achieved by the use of Arduino unit that continuously monitor and records the energy meter reading in its permanent (non- volatile) memory location. This system continuously records the reading and the live meter reading can be displayed on webpage to the consumer on request. This system also can be used to disconnect the power supply of the house when needed.

II. METHODS AND MATERIAL

A.ENERGY METER:

Energy Meter or Watt-Hour Meter is an electrical instrument that measures the amount of electrical energy used by the consumers. Utilities are one of the electrical departments, which install these instruments at every place like homes, industries, organizations, commercial buildings to charge for the electricity consumption by loads such as lights, fans, refrigerator, and other home appliances. The basic unit of power is watts and it is measured by using a watt meter. One thousand watts make one kilowatt. If one uses one kilowatt in one-hour duration, one unit of energy gets consumed. So energy meters measure the rapid voltage and currents, calculate their product and give instantaneous power. This power is integrated over a time interval, which gives the energy utilized over that time period.

B.NODE-MCU (ESP8266):

Node MCU is an open source IOT platform. It includes firmware which runs on the ESP8266 Wi-Fi SOC from Express if Systems, and hardware which is based on the ESP-12 module. The term "Node MCU" by default refers to the firmware rather than the development kits. The firmware uses the LUA scripting language. It is based on the LUA project, and built on the Express if Non-OS SDK for ESP8266. It uses many open source projects, such as LUA-CJISON and SPIFFS.



Fig.2 NODE-MCU (ESP8266)

C.CURRENT SENSOR:

A current sensor is a device that detects electric current in a wire, and generates a signal proportional to that current. The generated signal could be analog voltage or current or even a digital output. The generated signal can be then used to display the measured current in an ammeter, or can be stored for further analysis in a data acquisition system, or can be used for the purpose of control.

Fig.3 current sensor

D.VOLTAGE REGULATOR:

Voltage sources in a circuit may have fluctuations resulting in not providing fixed voltage outputs. A voltage regulator IC maintains the output voltage at a constant value. 7805 IC, a member of 78xx series of fixed linear voltage regulators used to maintain such fluctuations, is a popular voltage regulator integrated circuit (IC). The xx in 78xx indicates the output voltage it provides. 7805 IC provides +5 volts regulated power supply with provisions to add a heat sink.

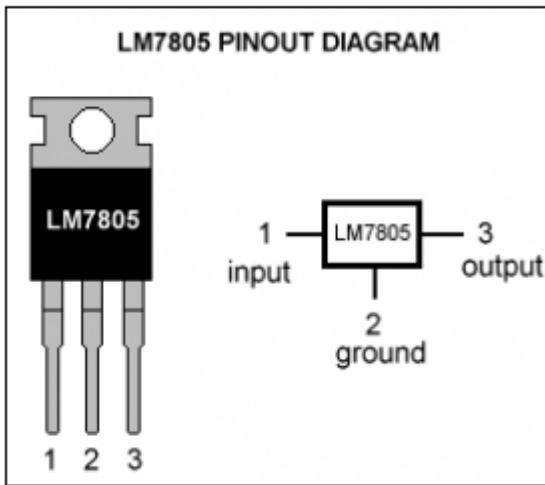

Fig.4 voltage regulator

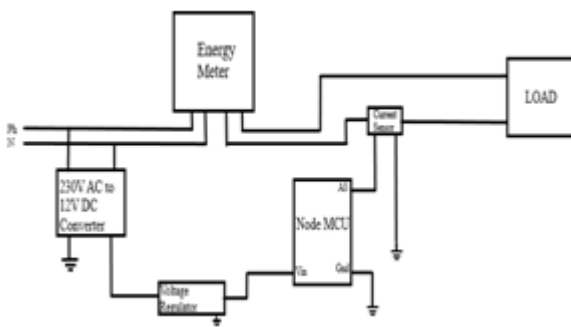

Fig.5 Block Diagram of IOT Based Smart Energy Meter

III. WORKING PRINCIPLE

When the Energy Meter gets supply from the main (substation or power station) to the input terminals of the energy meter. Generally energy meter has two input terminals and two output terminals. From the input terminals of the energy meter input is given to ac converter (220v to 12v) by shorting the both input of energy meter and input terminals of the ac converter. This converter converts 230V AC to 12V DC. This 12V DC supply is output of the converter. This output is given as input to the voltage regulator. The output of the regulator is given as input to the Node MCU to Vin. The output of the energy meter is given to the load (2 terminals). One of the output terminals is connected to lamp load by shorting the lamp terminal. And second terminal is connected to the switches through the current sensor. The current sensor has two terminals. One terminal is grounded and the another terminal is connected to the analog

output terminal of Node MCU. When we give supply to the energy meter. It transfer to the load through the output terminal passing through the current sensor. This current sensor senses the current that passes through the wire and gives it to the Node MCU. By Node MCU we connected to the Blynk app interfaces. It is IOT platform used to control Arduino, Node MCU. In Blynk app create a new project file name is IOT based smart energy meter. A page is appear hence we create a valued display settings to display the how much load we consume and a labeled value display it will display the cost of power consumed by the load in one month and last finally we insert a notification bar in a Blynk app for when the load is access then the threshold value it send notification alert to the Mobile through the Wi-Fi module of Node MCU.



Fig. 5 Proposed model

IV. RESULTS AND DISCUSSION

Firstly we have to switch on the mains. Current sensor senses the power utilized by the load. This gives output in analog form. The output of the sensor is supplied as input to the analog input part in the Arduino Nano Board. Arduino board has inbuilt analog to digital convertor which converts analog input of power to digital output. This digital output is displayed on LCD display in form of Watts. There is a set point value; when the power utilized by the load exceeds the set point value LCD displays "Theft detected". The Node MCU is used to connect

internet with the monitoring hardware system. The power utilized by the load is displayed in the cloud viz, Thing Speak cloud in graphical format. It shows time to time power utilization of the load/loads connected to the system. Energy Monitoring using IOT is an innovative application of internet of things developed to control home appliances remotely over the cloud from anywhere in the world. In the proposed project current sensor is used to sense the current and display it on internet using IoT. The system updates the information in every 1 to 2 seconds on the internet using public cloud THINGSPEAK. In the present system, energy load consumption is accessed using Wi-Fi and it will help consumers to avoid unwanted use of electricity. IoT system where a user can monitor energy consumption and pay the bill Online can be made. Also, a system where a user can receive SMS, when he/she crosses threshold of electricity usage slab can be equipped. We can make a system which can send SMS to the concerned meter reading man of that area when theft is detected at consumer end. Also using cloud analytics we can predict future energy consumptions.

V. ACKNOWLEDGMENT

We express our thanks to the support given by the management in completing our project. We express our sincere gratitude & deep sense of respect to Dr. G.Joga Rao, Head, department of Electrical & Electronics Engineering. We express our sincere thanks to our project guide Dr. DVN Ananth Assistant Professor for his support to completion of this project. We thankful to the teaching and non-teaching staff of Electrical department for their direct as well as indirect help in our project.

VI. REFERENCES

- [1]. Himshekhar Das, L.C.Saikia, "GSM Enabled Smart Energy Meter and Automation of Home Appliances", PP-978-1-4678-6503-1, 2015 IEEE.
- [2]. Ofoegbu Osita Edward, "An Energy Meter Reader with Load Control Capacity and Secure Switching Using a Password Based Relay Circuit", PP-978-1-4799-8311-7, 'Annual Global Online Conference on Information and Computer Technology', IEEE 2014.
- [3]. Yingying Cheng, Huaxiao Yang, Ji Xiao, Xingzhe Hou, "Running State Evaluation Of Electric Energy Meter", PP978-1-4799-4565-8, 'Workshop on Electronics, Computer and Applications', IEEE2014.
- [4]. Sahana M N, Anjana S, Ankith S, K Natarajan, K R Shobha, "Home energy management leveraging open IoT protocol stack ", PP- 978-1-4673-6670-0, 'Recent Advances in Intelligent Computational Systems (RAICS)', IEEE2015.
- [5]. Luigi Martirano, Matteo Manganelli, Danilo Sbordone, "Design and classification of smart metering systems for the energy diagnosis of buildings" IEEE2015.
- [6]. J. Widmer, Landis, "Billing metering using sampled values according IEC 61850-9-2 for substations", IEEE2014.
- [7]. G. Joga Rao, K. Siva Shankar " Smart Solar Charging Meter", International Journal of Scientific Research in Science, Engineering and Technology(IJSRSET), Print ISSN : 2395-1990, Online ISSN : 2394-4099, Volume 4 Issue 4, pp.701-704, March-April 2018. DOI : 10.32628/IJSRSET1844257
- [8]. Dr.G.joga Rao, G.S.N.M Venkatesh Simulation of an Automatic Meter Reading System for Smart Metering by using ASK/OOK Modulation in Rural Smart Micro-grids, International Journal of Engineering & Technology (IJET) Vol 9 No 3 Jun-Jul 2017 PP1511-1523 DOI: 10.21817/ijet/2017/v9i3/170903501
- [9]. Cheng Pang, Valierry Vyatkin, Yinbai Deng, Majidi Sorouri, "Virtual smart metering in automation and simulation of energy efficient lightning system" IEEE2013.

- [10]. Amit Bhimte, Rohit K.Mathew, Kumaravel S, "Development of smart energy meter in labview for power distribution systems", "IEEE INDICON 2015 1570186881",2015.
- [11]. Mr G Joga Rao, BPSK Modulation and Demodulation with Power Line Carrier Communication and GSM Communication for Smart Metering, International Journal of Power Electronics and Drive System ISSN: 2088-8694, Vol. 7, No. 3, pp. 713-722 Sept- 2016. DOI: <http://doi.org/10.11591/ijpeds.v7.i3.pp713-722>

Cite this article as :

D.V.N. Ananth, G. Joga Rao, Ch. Satish, J. Shyam, K.Santosh, U.V.V.S.S.V.Prasad, K. Ramya, "Smart Electricity Billing Using Node-MCU", International Journal of Scientific Research in Science, Engineering and Technology (IJSRSET), Online ISSN : 2394-4099, Print ISSN : 2395-1990, Volume 6 Issue 2, pp. 287-292, March-April 2019. Available at doi : <https://doi.org/10.32628/IJSRSET196269>
Journal URL : <http://ijsrset.com/IJSRSET196269>