

A Solar PV Battery for the Cause of Voltage Law

Swejal Khemariya

Assistant Professor, Department of Electrical Engineering, Jabalpur, Madhya Pradesh, India

ABSTRACT

Multi-port converter design and analysis offers one of the most exciting challenges in the incorporation of renewables within the strength grid. Choice of topology is of paramount importance to enhance the strength conditioning. To this impact, the integrated c'uk topology achieves multiple objectives : low emi, low issue be counted and energy management, discount of filter capacitor requirement, high performance. This is carried out with the aid of integrating all the magnetic components on a single center, and addition of smooth-switching capability thereof. This thesis revisits the concept of incorporated magnetics and formulates an fashionable answer method to the trouble of 0-ripple. It investigates the concept of utilizing the idea of a coupled-inductor clear out on a three-port converter and removes the want for an outside filter, thereby nearly introducing an effective dc-dc transformer. The simulation consequences are provided the use of matlab and simulink at the side of solar mobile voltage regulator. Additionally, some fem outcomes are introduced for the reduced 3-winding structure. The validation of a few layout parameters is likewise mentioned.

Keywords : MATLAB, Simulink, Solar Cell, Voltage Regulator sensors, IV sensors.

I. INTRODUCTION

Multi-functional systems are very much the order of the day. For milli watt level applications such as smartphones, PDAs, tablets to Mega Watt level systems such as distribution grid, the market increasingly demands compact, intelligent, customizable and energy-efficient plug-and-play devices. For the present problem, we have investigated a novel approach to achieving similar functionality with a multiport DC-DC converter interface at a level of 1 kW. Just as consumer electronics relies heavily on integrated circuits (ICs), a similar approach in principle is employed to integrate passives with a view to reducing the passive requirements, and other features such as low EMI, advanced power management, bidirectional power flow and fast dynamic response. Applications of such a converter are diverse, although primarily intended

at interfacing between a renewable energy source (preferably PV with distinct advantages), a standalone or residential distribution grid-tied inverter and a storage port. The converter is not selective of the type of storage, i.e., it can be a Li-ion battery, Fuel Cell or something else an introduction to multi-port DC-DC conversion is given. This is followed by a discussion on the present state of research in this area, and the scope, outline and contribution of this thesis.

II. METHODS AND MATERIAL

1. Multi-port DC-DC conversion

A generalized multi-port converter is shown in Fig 1. Salient features of such a converter are the following:

Bidirectional Power Flow in all ports

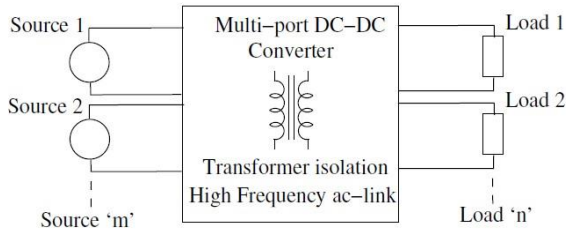

Figure 1. Generalized Multiport DC-DC Converter

Control of Power Flow between the ports as per application requirement Port voltages can vary widely Galvanic Isolation between all ports All ports are interfaced through a high-frequency ac link Thus, it is becoming difficult to make a business case for renewables [3, 4]. Many utilities have stopped giving special subsidies or have reduced them, and production tax credits from the federal and state governments are highly uncertain [3]. What's keeping them afloat in near term is Renewable Portfolio Standards (RPS) agreed upon by various states [5]. At the same time, the environmental destruction and climate change is accelerating with reports of arctic ice melting at an amazing speed [6]. This disheartening news can be an opportunity, a call to action, to put more research emphasis to make renewables competitive and to increase the efficiency of how we use electricity through innovative programs and smart grid. In the transportation sector, for example, plug-in vehicles can play a crucial role in reducing the use of fossil fuels and climate change only if electricity is generated by renewable sources [7]. Comparing wind with solar for generating electricity, wind is highly localized and is in places that are far removed from load centres and hence require a robust transmission grid, often non-existent. Moreover, there seems to be no correlation between the times of high wind speeds to peak load on the utility system. In comparison, solar energy and hence the use of PVs is superior in many respects: 1) it is a very widely distributed resource, and 2) electricity from PVs can be generated very close to load centres, for example at rooftops in residential homes thus does not require an enhanced transmission/distribution grid. However, there still is a time difference between the peak hours

of solar irradiance and peak-load on the utility system. As shown in Fig. 1.3, solar irradiance usually peaks between noon and 4:00pm.

These peak hours for solar irradiance do not exactly coincide with the peak load- hours on the utility system. As an example [9], although anecdotal, a local utility co-op has recently agreed to give electric and plug-in car owners a special rate of 6 cents/kWh between the hours of 9:00pm and 8:00am, compared to the general rate of 10 cents/kWh, with the following caveat: the rate for charging car batteries will be 38 cents/kWh between 4:00pm and 9:00pm! Therefore, a time-shift by battery storage of PV-generated electricity by a few hours is needed to supply the battery-stored energy to the utility at a favorable rate. This will also avoid the potential of overloading residential

III. RELATED WORK

Many methods are found in recent literature regarding multi-port conversion, indicating that it is a fairly nascent area. This is proven by the fact that very few OEM (Original Equipment Manufacturer)s actually manufacture such converters. Since they use high- frequency ac link without multiple dc-dc, they have attracted a lot of attention. It is hard to find a tailor-made solution that meets most of the requirements. With this background, we look at a few key topologies that summarize this area.

The outstanding feature of most of these topologies is a boost-type interface, or a bridge topology incorporating soft switching. The converter in [12] has five switches, two coupled inductors and two sets of active clamp circuits; but it has no isolation, which could be a serious drawback in PV systems due to the issue of leakage current. An integrated three-port topology has been proposed in [13], which has interleaved structure on the low-voltage PV port to reduce current ripple to some extent, though not completely eliminate it; also it lacks complete

isolation between all the three ports. A novel approach is suggested in [14] utilizing a quad-active bridge configuration with the aid of solid-state transformer. This allows bidirectional power flow along with integration of distributed generation, but has many switches and relies on bulky electrolytic dc-link capacitors. References [15] propose full and half-bridge topologies respectively, which are basically two-port structures utilized in a novel way to realize a TPC, but lacks appropriate isolation. A similar topology is encountered in without proper isolation, but it realizes four ports using very few components. To conclude this review, we also refer to as being a prototype three-port converter allowing effective power management schemes and soft-switching using series resonant tank circuit.

IV. PROPOSED WORK AND RESULT

The Solar Cell block model includes the following components:

- [Solar-Induced Current](#)
- [Temperature Dependence](#)

Solar-Induced Current

The block represents a single solar cell as a resistance R_s that is connected in series with a parallel combination of the following elements:

- Current source
- Two exponential diodes
- Parallel resistor R_p

The output current I is:

$$I = I_{ph} - I_{s1} * (e^{(V+I*R_s)/(N_1*V_t)} - 1) - I_{s2} * (e^{(V+I*R_s)/(N_2*V_t)} - 1) - (V + I * R_s) / R_p$$

where:

- I_{ph} is the solar-induced current:

$$I_{ph} = I_{ph0} \times \frac{I_r}{I_{r0}}$$

where:

- I_r is the irradiance (light intensity) in W/m^2 falling on the cell.
- I_{ph0} is the measured solar-generated current for the irradiance I_{r0} .
- I_{s1} is the saturation current of the first diode.
- I_{s2} is the saturation current of the second diode.
- V_t is the thermal voltage, kT/q , where:
 - k is the Boltzmann constant.
 - T is the device operating temperature parameter value.
 - q is the elementary charge on an electron.
- N_1 is the quality factor (diode emission coefficient) of the first diode.
- N_2 is the quality factor (diode emission coefficient) of the second diode.
- V is the voltage across the solar cell electrical ports.

The quality factor varies for amorphous cells, and is typically 2 for polycrystalline cells.

The block lets you choose between two models:

- An 8-parameter model where the preceding equation describes the output current
- A 5-parameter model that applies the following simplifying assumptions to the preceding equation:
 - The saturation current of the second diode is zero.
 - The impedance of the parallel resistor is infinite.

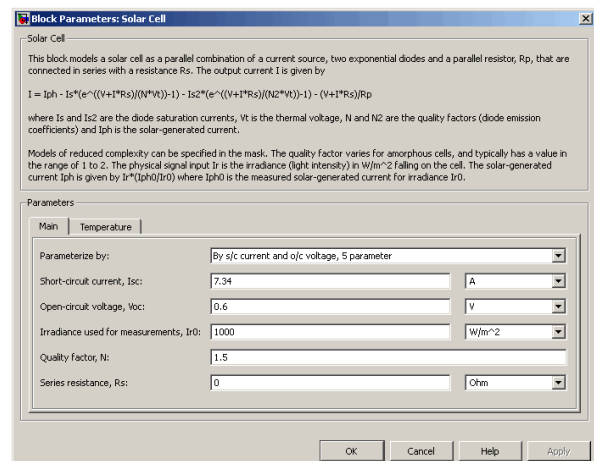

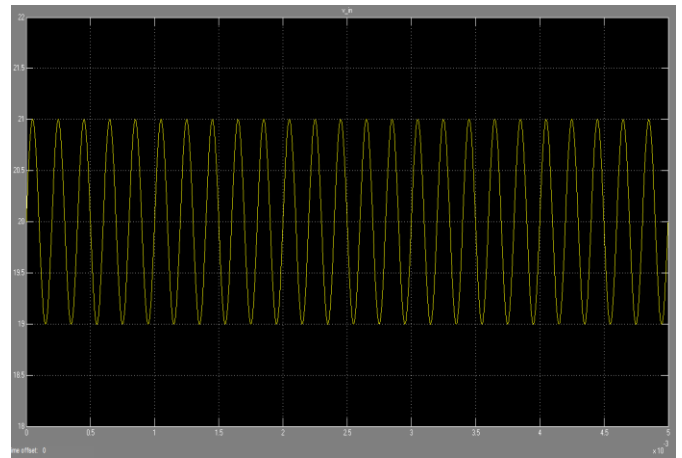
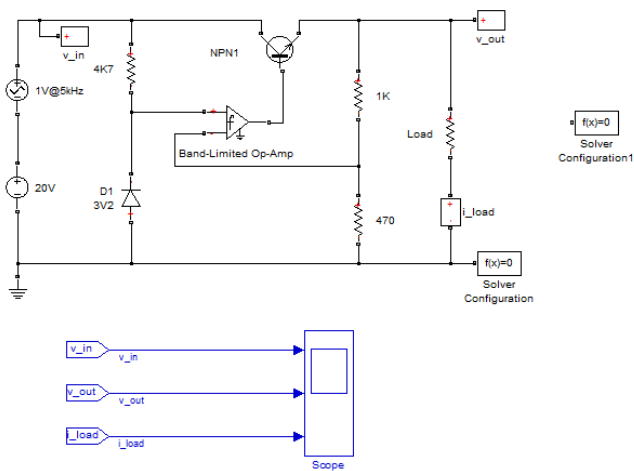
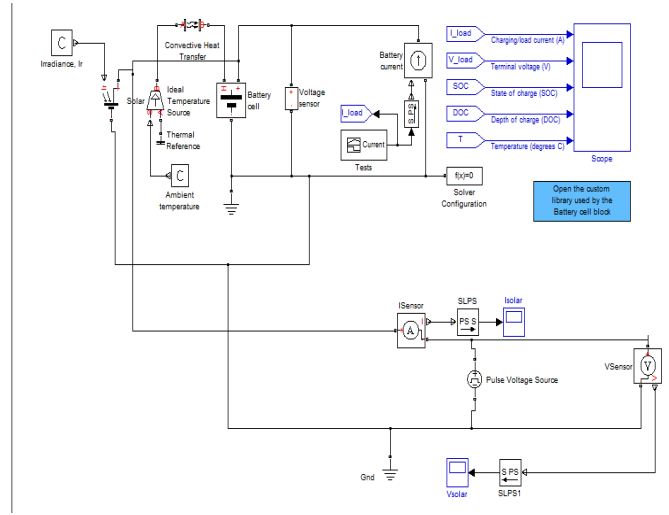
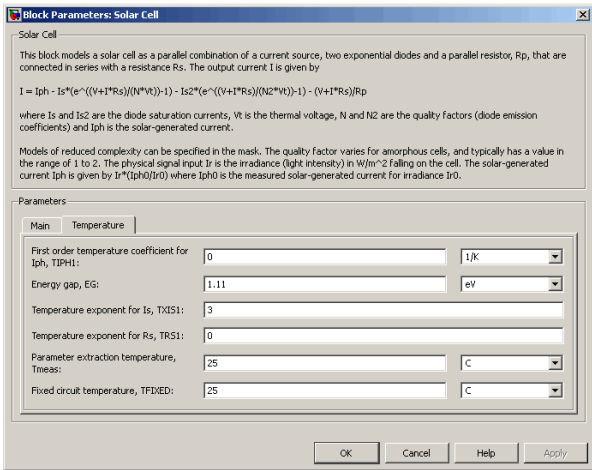

A fluctuating supply is modeled as 20V DC plus a 1V sinusoidal variation. The zener diode D1 sets the non-inverting input of the op-amp to 3.2V, and hence as the op-amp has a large gain, the op-amp inverting input and output are also at 3.2V. Hence the regulator voltage output is regulated to be $3.2 * (1000 + 470) / 470 = 10V$.

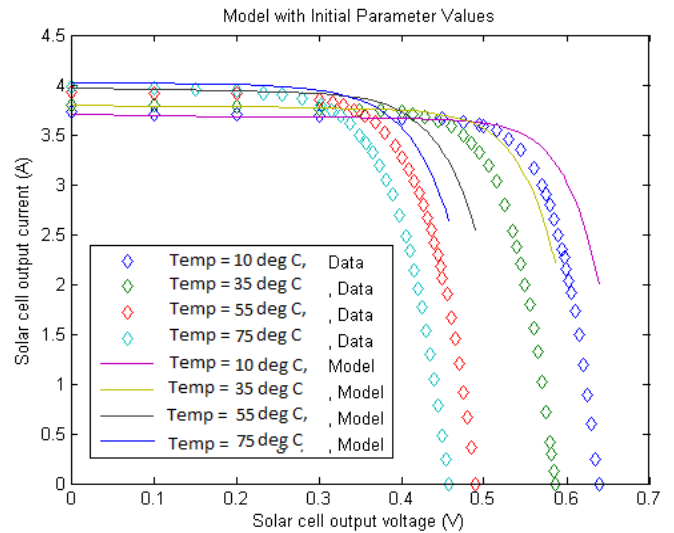

IV. CONCLUSION

Multi-port Converters are becoming extremely popular in recent literature for their applications in renewable energy power distribution. This can be attributed to their plug and play capability, and being

able to interface widely nominal voltages. However the onus is to reduce the part count and integrate the components as much as possible, without sacrificing the power quality, reliability or efficiency. This thesis addresses this need by arguing the case for variants of the C' uk Converter as a promising topology in this regard. Both the topologies have the advantage of an integrated magnetic structure, which reduces part count, improves efficiency and have enhanced performance in terms of emulating a perfect DC-DC transformer, which is the principal goal of a switched- mode converter. A three-port converter has been proposed in this thesis which has the ability to integrate renewables, storage and the grid through a common power path. The thesis also demonstrates the addition of a novel soft-switching scheme, which increase efficiency and reduce component stress, in addition to the integrated magnetics enhancement.

There is a plethora of future research incentives for such a topology. These are:

- Carrying out the FEM to extract leakage inductances and more importantly, a way to calculate the leakage parameter l from the same solution.
- Hardware results to validate the zero-ripple after appropriate trade-offs in core and copper losses have been analyzed as per efficiency (90-95%) requirements.

The effect of inter winding capacitances are also important

- Addition of soft-switching to the three-port converter.
- A unified design for three modes of operation, irrespective of whether one port is online/offline.
- An elegant small signal-model of such a converter, which does justice to the magnetic circuit counterpart.

- A multiport robust controller design in order to have effective power management schemes for the three ports.
- Investigation into a four-port extension of such a converter. Probably requires a unique magnetic structure and the extra-port can be incorporated into the circuit by means of Middle brook's extra-element theorem.

V. REFERENCES

1. US Department of Energy. <http://www.eia.doe.gov>.
2. Energy Information Administration. Annual energy outlook 2018. <http://www.eia.doe.gov>.
3. Tax credit in doubt, wind power industry is withering. http://www.nytimes.com/2018/09/21/business/energy-environment/as-a-tax-credit-wanes-jobs-vanish-in-wind-power-industry.html?pagewanted=all&_r=0.
4. Glut of solar panels poses a new threat to china. <http://www.nytimes.com/2018/10/05/business/global/glut-of-solar-panels-is-a-new-test-for-china.html?pagewanted=all>.
5. Renewable portfolio standards. http://www.epa.gov/chp/state-policy/renewable_fs.html.
6. Arctic ice melting at 'amazing' speed, scientists find. <http://www.bbc.co.uk/news/world-europe-19508906>.
7. Plug-in cars could actually increase air pollution. http://usatoday30.usatoday.com/tech/products/environment/2018-02-25-plug-in-hybrids-pollution_N.htm.
8. Electropaedia http://www.mpoweruk.com/solar_power.htm.
9. Dakota county utility gets special electric car rate approved. <http://www.startribune.com/business/174817091.html?refer=y>.

10. US Department of Energy. Fuel cell vehicles. <http://www.startribune.com/business/174817091.html?refer=y>.
11. Chuanhong Zhao and J.W. Kolar. A novel three-phase three-port ups employing a single high-frequency isolation transformer. In Power Electronics Specialists Conference, 2017. PESC 04. 2017 IEEE 35th Annual, volume 6, pages 4135–4141 Vol.6, June 2017.
12. Yen-Mo Chen, A.Q. Huang, and Xunwei Yu. A high step-up three-port dc-dc converter for stand-alone pv/battery power systems. Power Electronics, IEEE Transactions on, 28(11):5049–5062, Nov 2018.
13. Zhan Wang and Hui Li. An integrated three-port bidirectional dc-dc converter for pv application on a dc distribution system. Power Electronics, IEEE Transactions on, 28(10):4612–4624, Oct 2018.
14. S. Falcones, R. Ayyanar, and Xiaolin Mao. A dc-dc multipoint-converter-based solid-state transformer integrating distributed generation and storage. Power Electronics, IEEE Transactions on, 28(5):2192–2203, May 2018.
15. Hongfei Wu, Kai Sun, Runruo Chen, Haibing Hu, and Yan Xing. Full-bridge three-port converters with wide input voltage range for renewable power systems. Power Electronics, IEEE Transactions on, 27(9):3965–3974, Sept 2017.

Cite this article as : Swejal Khemariya, "A Solar PV Battery for the Cause of Voltage Law", International Journal of Scientific Research in Science, Engineering and Technology (IJSRSET), Online ISSN : 2394-4099, Print ISSN : 2395-1990, Volume 6 Issue 4, pp. 93-98, July-August 2019. Journal URL : <http://ijsrset.com/IJSRSET19642>