

Automatic Street Lighting Control System Using Microcontroller and Sensors

Jagdish Patel¹, Saloni Thorat², Srushti Dusane²

¹Assistant Professor, E&TC Engineering Department, SITRC, Nashik, Maharashtra, India

²E&TC Engineering Department, SITRC, Nashik, Maharashtra, India

ABSTRACT

Now-a-days the amount of power consumed by lighting and streets shares a major energy demand. Nowadays, human has become too busy, and is unable to find time even to switch off the lights wherever not necessary. Generally, street lights are switched on for whole night and during the day, they are switched off. But during the night time, street lights are not necessary if there is no traffic. Saving of this energy is very important factor these days as energy resources are getting reduced day by day. To overcome from this issue, a proper energy saving methods and lighting control to be implemented. The proposed work is to have two controls like, one is to switch of lights during no vehicle moments in streets and automatically switch it on when vehicles arrive and the other modes are to give less intensity light for pedestrian and to switch on bright mode during vehicle moments at sides on the roads. In this work the sensor is used for street arrangement, the Photo diodes and IR sensors are used to sense vehicle moments. The control signals of sensors have been fed to microcontroller 8051. Moreover the automatic and intelligent control schemes are required to control the complex lighting system due to growth of cities and standard of living.

Keywords : Microcontroller, Streetlights, Photo Diodes, IR Sensor

I. INTRODUCTION

Generally, street light control system is a simple concept which uses a transistor to turn ON in the night time and turn OFF during the day time. Providing street lighting is one of the most important and expensive responsibilities of a city. Energy efficient technologies and design mechanism can reduce cost of the street lighting drastically. The work related to design of energy efficient street lighting system mainly focuses on using sensor based technology. The entire process can be done by a using a sensor namely LDR (Light dependent resistor). Nowadays conserving the energy is an essential part and day by day energy resources are getting decreased. So our next generations may face a lot of problems due to this lack of resources. This system doesn't need

a manual operation to turn ON/OFF the street lights. The street light system detects whether there is need of light or not. This system was designed to detect the light automatically and switch on's light. The design makes use of a microcontroller to control the outputs when it receives input from the resistor.

This design can be used in different areas like Street lights, Public parks, and lights outside of houses. A report was made to present an efficient street lighting system with reduced power consumption in comparison to other normal lighting systems by knowing on this LED's are more efficient than any other diodes or bulbs.

II. RELATED WORK

1. Optimization of a standalone street light system with consideration of lighting control. [1]

This paper aims at designing and executing the advanced development of embedded systems for energy saving of street lamps. Nowadays, the human has become too busy and is unable to find time even to switch the lights wherever not necessary. This paper gives the best solution for electrical power wastage. Also, the manual operation of the lighting system could eliminate. In this article, Light Emitting Diode (LED) is used. In this system, the main drawback was switching arrays of street lights were not possible. Only Single Street can be operated.

2. The efficient control algorithm for a smart solar street light. [2]

This proposed system works on solar energy. The street light gets charged on sun energy in the daytime, and it is consumed at night. The sensors get automatically ON in the darkness and OFF in daytime. When the battery of solar street light gets discharged, it switched to RTC controller. If the weather changes, the sun energy is not sufficient to charge the solar batteries. Hence it may lead to the inconvenience of the lighting of the street light.

3. E-Street zone-automatic Street light based on the movement of vehicles. [3]

Every street light can be integrated with an IR sensor which detects the movement of vehicles. When the vehicle passes, light gets illuminated. Due to this electricity can be consumed less and energy can be saved up to some extent. A solar panel has been installed, and hence it gets charged by sunlight. But it is impractical as street lights are also useful for the people walking by the roadside and this sensor only goes on when the vehicle passes it. Also, it is costly due to IR sensors used in every single street light.

III. PROBLEM STATEMENT

Lights contain chips. Chips consists Microcontroller along with various sensors like CO2 sensor, fog sensor, light intensity sensor, noise sensor and GSM modules for wireless data sending and receiving between concentrator and PC. The data from the chips would get on a remote concentrator (PC), and the PC would also transfer the controlling action to the chip. According to the survey of variation in the intensity of light in the field area, an efficient programming would be done to ensure the least consumption of energy. The emissions in the atmospheres would detect along with the use of energy and any theft of electricity.

IV. METHODOLOGY

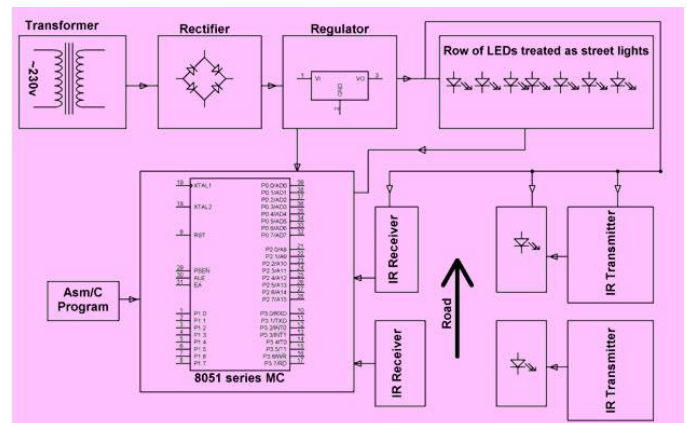

Figure-1: Block Diagram of the Proposed System

Automatic control of street lights is designed to turn on and turn off street lights automatically. This proposed system checks the amount of light. If light is 80 percent available, it automatically turns off street lights. But if amount of light is less than 80 percent, this project will automatically turn on street lights. One can also adjust it according to its requirement. Light sensor is used to detect intensity of light. When LDR allows the current to flow the block diagram of circuitry goes into working condition. IR sensors start emitting IR rays via IR transmitters. The IR diodes are placed on one side of the road and photodiodes are placed on the other

side of the road, directly facing the IR diodes. When there is no vehicle on the highway. In this case, the IR radiation emitted from the IR diode directly falls on the photodiode which is exactly opposite to it. This causes the photodiode to fall in conduction state. This implies that photodiode conducts and current passes through it. But as soon as any vehicle crosses or obstructs the path of IR rays and prohibits it to reach at IR receivers the microcontroller starts getting the blockage signals. The programming installed in microcontroller starts running which basically presented here allows three street lights to glow that are- the light in front of vehicle, behind the vehicle and parallel to vehicle making backward and forward street visible. Transformer converts the high 230V AC to 12V AC. Rectifier converts it into DC. For voltage regulation we are using LM 7805 and 7812 to produce ripple free 5 and 12 volts DC constant supply. Emitting Diode (LED) replaces HID lamps by engaging a programmable microcontroller that controls the street light on/off conditions.

A. Light Dependent Resistor

A Light Dependent Resistor (LDR) is also called a photo resistor or a cadmium sulphide (CdS) cell. It is also called a photoconductor. It is basically a photocell that works on the principle of photoconductivity. The passive component is basically a resistor whose resistance value decreases when the intensity of light decreases. This optoelectronic device is mostly used in light varying sensor circuit, and light and dark activated switching circuits. Some of its applications include camera light meters, street lights, clock radios, light beam alarms, reflective smoke alarms and outdoor clocks. LDR used in street light automatically switches ON when the night falls and turns OFF when the sun rises. The snake like track shown is the Cadmium Sulphide (CdS) film which also passes through the sides.

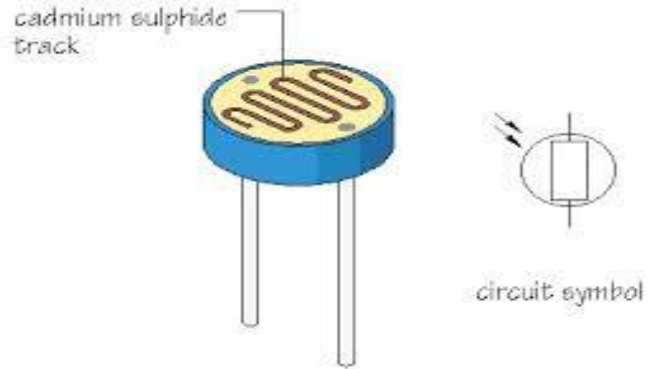

Figure-2: LDR sensor

On the top and bottom are metal films which are connected to the terminal leads. It is designed in such a way as to provide maximum possible contact area with the two metal films. The structure is housed in a clear plastic or resin case, to provide free access to external light. As explained above, the main component for the construction of LDR is cadmium sulphide (CdS), which is used as the photoconductor and contains no or very few electrons when not illuminated. In the absence of light it is designed to have a high resistance in the range of mega ohms. As soon as light falls on the sensor, the electrons are liberated and the conductivity of the material increases.

B. Microcontroller

A Microcontroller has all the necessary components which a microprocessor possesses and invariably it poses ROM, RAM, Serial Port, timers, interrupts Input-Output ports, and a clock circuit. The microcontroller always focus on the chip facility and it is more prominent in the case of serial ports, analog-to-digital converters, timers, counters, read-only memory, parallel input, interrupt control, random access memory, and output ports. The concept of the 8051 microcontroller arises from here and here we will discuss in depth about the various aspects, uses, programming and other features of 8051 microcontrollers.

V. CONCLUSION

This proposed system is a cost effective, practical, eco-friendly and the safest way to save energy. It clearly tackles the two problems that world is facing today, saving of energy and also disposal of incandescent lamps very efficiently. According to statistical data we can save more that 40 % of electrical energy that is now consumed by the highways. Initial cost and maintenance can be the draw backs of this system. But with the advancement in technology and good resource planning the cost of the project can be cut down and also with the use of good equipment the maintenance can also be reduced in terms of periodic checks. The LEDs have long life & emit cool light, donor have any toxic material and can be used for fast switching. For these reasons our system presents far more advantages which can over shadow the present limitations. Keeping in view the long term benefits and the initial cost would never be a problem as the investment return time is very less. The proposed system has scope in various other applications like for providing lighting in industries, campuses and parking lots of huge shopping malls. This can also be used for surveillance in corporate campuses and industries.

VI. REFERENCES

- [1]. Farah Ramadhani, and Kamalrulnizam Abu Bakar, and Muham-Mad Gary Shafer. "Optimisation of standalone street light system with consideration of lighting control", IEEE, 2013.
- [2]. Jain, Abhilasha, and Chandrasekhar Nagarajan. "Efficient-Control Algorithm for a Smart Solar Street Light." Next Generation Mobile Applications, Services and Technologies, 2015 9th International Conference on. IEEE, 2015.
- [3]. P Arvind and V.Kishore . "E-Street Zone-Automatic Streetlight based on the Movement of Vehicles", IJST 2016.
- [4]. Energy efficient Smart Street Light, IEEE conference 2017, Ravi kishorekodali and Subbachary Yerroju, Department of Electronics and Communication Engineering, National Institute of Technology, Warangal.
- [5]. Solar LED street light system with Automatic Scheme-2017, Omveer Singh, IEEE SR.Member, Electrical Engineering Department, Greater Buddha University, Tushar Singh Sisodia Electrical Department, Greater Noida.
- [6]. A smart street light intensity optimizer, IEEE Conference 2017, Bilam Roy and Jayita Datta, Department of Applied Electronics and Instrumentation Engineering, Guru Nanak Institute of Technology, Kolkata, W.B., India.
- [7]. Internet of Things Based Intelligence Street Lighting System for Smart city, IJIRSET, May 2016, Parkash, Prabhu V, Dandu Rajendra.
- [8]. Automatic Street Light Control System using Wireless Sensor Networks, IEEE-2017. Dhiraj Sunehra, SMIEEEE, JNTU college of Engineering, Department of Electronics and Communication Engineering, Telangana, India.

Cite this article as :

Jagdish Patel, Saloni Thorat, Srushti Dusane, "Automatic Street Lighting Control System Using Microcontroller and Sensors", International Journal of Scientific Research in Science, Engineering and Technology (IJSRSET), Online ISSN : 2394-4099, Print ISSN : 2395-1990, Volume 7 Issue 2, pp. 571-574, March-April 2020. Available at doi : <https://doi.org/10.32628/IJSRSET2072114>
Journal URL : <http://ijsrset.com/IJSRSET2072114>